

## EXECUTIVE SUMMARY

What follows is a summary of this document.

### 1. AN APPROACH TO FOUR GENERAL QUESTIONS ABOUT THE MATHEMATICS TEACHER

Teacher training has become one of the main foci of research in mathematics education in the past fifteen years. Interest focuses on four central questions:

1. What characterises effective and efficient action by the teacher in the mathematics classroom?
2. What should be the knowledge, capacities, and attitudes of a teacher who acts effectively and efficiently?
3. How can initial training programs for high school mathematics teachers be designed and implemented to support and foster the development of this knowledge and these capacities and attitudes?
4. What characterises the learning processes of future high school mathematics teachers who participate in this kind of initial training program?

This study is framed by the area of action defined by these four questions. For each, I determine a specific work context. For the first question, I propose, from a conceptual perspective, a description of the ideal procedure that the mathematics teacher should perform when designing, putting into practice, and evaluating didactic units (didactic analysis). Second, I establish the knowledge and abilities that the teacher should have and develop to perform didactic analysis (didactic knowledge). I focus attention on the process of curriculum design (planning of didactic units), in the context of the course *Mathematics Education in High School*

Gómez, P. (2007). *Desarrollo del conocimiento didáctico en un plan de formación de profesores de matemáticas de secundaria*. Tesis doctoral no publicada, Universidad de Granada, Granada.

at the University of Granada and therefore refer to the initial training of high school mathematics teachers in Spain. Finally, I study and characterise (from an evolutionary and socio-cultural perspective) the learning of the future teachers who took this course in the 2000-01 academic year.

The problem I tackle in this project arises from the convergence of two cases in the training of high school mathematics teachers developed at the end of the 1980s and in the 90s. The first took place in Granada, Spain, in the context of the initial training of future mathematics teachers at the University of Granada, and the second in Bogotá, Colombia, in the context of the projects for continuing education for high school teachers developed by “una empresa docente”, a centre for research in mathematics education at the University of the Andes.

At the end of the 90s, Luis Rico began a line of research in teacher training whose main focus was “the evaluation of the model of the curriculum organisers”. This model was the conceptual basis for the design of the second part of the course mentioned previously. Given that the idea of “evaluating the model” was complex and general, specific strategies were designed and developed for tackling this problem in the doctoral theses of Evelio Bedoya (2002) and José Ortiz (2002). The problem was defined in several dimensions: part of the model was chosen, the research experience was performed outside the context of the course, and specific objectives and designs were proposed.

I decided to address the problem from a different perspective characterised by: (a) specifying a meaning for the idea of “model of the curriculum organisers”; (b) focusing research on the learning of groups of future teachers; (c) concentrating on one of the analyses of didactic analysis; (d) studying the learning processes rather than the results; (e) exploring learning in groups of teachers; (f) determining a position on the learning of future teachers; and (g) performing research in the context of the course.

I assumed three roles throughout the project: curriculum designer, trainer and researcher. I developed the project in three periods, which correspond to these three roles. In the context I have defined, I established two general objectives for this project:

1. to advance in the conceptualisation of the activities of the high school mathematics teacher, his didactic knowledge and the design of initial training plans, and
2. to describe and characterise the development of the didactic knowledge of the groups of future teachers who participated in the course on Mathematics Education in High School in the academic year 2000-01, with respect to the curriculum organisers corresponding to subject matter analysis<sup>160</sup>.

I started from the idea that it is possible to achieve the first objective on the basis of a functional view of the initial training of high school mathematics teachers and their didactic knowledge. I thus establish the following specific objectives, which I will develop in greater detail throughout this document:

---

<sup>160</sup> Subject matter analysis is one of the analysis of didactic analysis. See next section.

- ◆ to introduce and characterise a meaning for the expression *didactic analysis*, as a conceptualisation of the teacher's performance in the activities of designing, developing and evaluating didactic units;
- ◆ to incorporate a meaning for the term *didactic knowledge*, as a conceptual tool for tackling the problem of the mathematics teacher's knowledge; and
- ◆ to advance in the conceptualisation and foundations of curricular design of the course Mathematics Education in High School at the University of Granada.

For the empirical approach that I established in the second general objective, I started from two ideas. The first is that it is possible to organise and characterise the development of didactic knowledge of the groups of future teachers who participated in the course. Second, that it is possible to tackle the learning of a group of future teachers from the socio-cultural perspective. I established two specific objectives:

- ◆ to describe, characterise and explain the *development of didactic knowledge* of the groups of future teachers who participated in a version of the course and
- ◆ to describe and characterise the activities outside the classroom of a group of future teachers when they prepare their work for the course.

This document is organised around these dimensions and has three parts. In the first, I describe and explain the foundations of the design and development of the course *Mathematics Education in High School*. In the second, I tackle the research problem concerning the learning of the groups of future teachers who participated in the course. This empirical approach is composed of four studies, in which I identify four states of the development of didactic knowledge of the groups of future teachers, characterise the evolution of the partial meanings that they developed throughout the course, explore and characterise how they put the didactic knowledge into practice in their final projects and characterise the processes of negotiation of meaning in a group of future teachers. In the third part, I summarise the results of the first two parts in order to explain and justify my contributions to the four general questions with which this section began.

## 2. DIDACTIC ANALYSIS

Here I respond to the first of the questions I formulated in the previous section, when I proposed didactic analysis as the ideal procedure that the teacher can use to design, put into practice, and evaluate didactic units. I focus attention on planning as a daily activity of the teacher and will tackle two problems that the teacher faces when planning a lesson: the gap between planning on the global and local levels (Rico, 1997a), which leads to the idea that many teachers see planning as the covering of the mathematical contents; and the planning paradox, that is, the issue of whether a teacher who assumes a constructivist position with respect to the students' learning can achieve some objectives by means of concrete, structured and design tasks that, at the same time, lead students to create their own constructions and that foster an environment of negotiation in the classroom (Simon y Tzur, 2004).

### 2.1. Procedure for Didactic Analysis

Didactic analysis, as a local planning procedure, is a level of the curriculum. With it, the teacher can specify (and differentiate) the goals, content, methodology and evaluation scheme of each topic in planning. I take a functional view of the mathematics curriculum, by virtue of which the student applies his knowledge using conceptual tools to solve problems. In local planning, the teacher focuses his attention on a specific topic in mathematics. On this level, the teacher's planning should take into account the complexity of the mathematical content from different points of view. In fact, the negotiation and construction of the multiplicity of meanings of the mathematical concepts should be one of the central purposes of interaction in the classroom. Planning of a didactic unit or of an hour of class should be grounded in the exploration and structuring of the different meanings of the mathematical structures that are the object of that lesson plan.

My proposal approaches the meaning of the mathematical concept by attending to three dimensions, systems of representation, conceptual structure and phenomenology:

- ◆ In the *systems of representation* I include the different ways in which the concept and its relations to other concepts can be represented.
- ◆ In the *conceptual structure* I include the relations of the concept to other concepts, attending both to the mathematical structure of which the concept forms part and the mathematical structure that this concept configures.
- ◆ In the *phenomenology* I include those phenomena (contexts, situations or problems) that can give meaning to the concept.

These three dimensions of the meaning of a concept in school mathematics reveal and organise one of the central questions of the problem of class planning: the multiplicity of meanings of a concept in school mathematics.

This multiplicity of meanings implies that, for the purpose of planning one hour of class or one didactic unit, the teacher should:

1. be familiar with the three dimensions that characterise the meaning of a concept in school mathematics<sup>161</sup>

and be able to:

2. gather the information necessary to enable him to identify these meanings and organise this information so that it is useful for planning;
3. select from this information the meanings that he considers relevant for instruction; and
4. use the information that emerges from the different meanings of the concept to design didactic units.

---

<sup>161</sup> In this study, I focus on the analysis of a concept and of the mathematical structures related to it. The topics in secondary education are not only concepts. They include, for example, operations between concepts, properties of concepts, results, procedures and systems of representation. All of these topics are framed by a mathematical structure and thus can be tackled with the tools of didactic analysis.

In the specific context of the planning of an hour of class or a didactic unit, the teacher can organise instruction based on four analyses :

1. *subject matter analysis*, as a procedure by which the teacher identifies and organises the multiplicity of meanings of a concept;
2. *cognitive analysis*, in which the teacher describes his hypotheses about how the students can progress in the construction of their knowledge of the mathematical structure when they face the tasks that will make up the teaching and learning activities;
3. *instruction analysis*, in which the teacher designs, analyses, and chooses the tasks that will constitute the teaching and learning activities that are the object of the teaching; and
4. *performance analysis*, in which the teacher determines the capacities that the students have developed and the difficulties that they may have expressed up to that point.

I use *didactic analysis* to refer to a cyclical procedure that includes these four analyses, attends to the factors conditioning the context and identifies the activities that the teacher should perform to organise the teaching of a specific mathematical content. The description of a cycle of didactic analysis follows the sequence described in Figure 91.

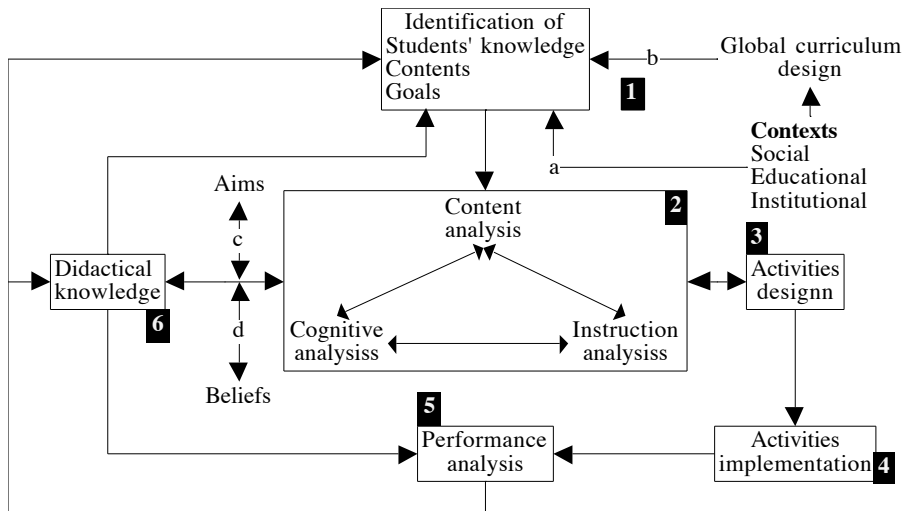

Figure 91. Cycle of didactic analysis

The cycle of didactic analysis begins with the determination of the content to be treated and the learning goals to be achieved. It starts from the teacher's perception of the students' understanding and is based on the results of the performance analysis in the previous cycle, taking into account the social, educational and institutional contexts that frame the instruction (box 1 of Figure 91). From this information, the teacher begins planning with subject matter analysis. The information that emerges from subject matter analysis serves as the basis for cognitive analysis, by identifying and organising the multiple meanings of the concept to be

taught. The cognitive analysis can then give rise to a revision of subject matter analysis. This relation between the analyses is also established with instruction analysis. Its formulation depends on and should be compatible with the results of the subject matter analysis and the cognitive analysis; but at the same time, performing it can generate the need to correct the prior versions of these analyses (box 2). In cognitive analysis, the teacher selects some reference meanings and, based on these and on the learning goals that have been imposed, identifies the capacities that he seeks to develop in the students. The teacher also formulates conjectures on the possible paths by which students can develop their learning when they tackle the tasks that make up the lesson. The teacher uses this information to design, evaluate and select these tasks. As a result, the choice of tasks that compose the activities should be consistent with the results of the three analyses, and the evaluation of these tasks in the light of the analyses can lead the teacher to perform a new cycle of analysis before choosing the definitive tasks that compose the teaching and learning activities (relation between boxes 2 and 3). The teacher puts these activities into practice (box 4) and, in doing so, analyses the students' actions to obtain information that serves as the starting point of a new cycle (box 5). Didactic knowledge (box 6) is the knowledge that the teacher brings into play during this process.

Each of the analyses is articulated around some notions, the *curriculum organisers*. For example, subject matter analysis includes the notions of system of representation, conceptual structure and phenomenology, which correspond to the three dimensions of the meaning of a concept in the context of school mathematics. For each notion, I adopt a theoretical meaning, a technical meaning and a practical meaning, which I will describe in the next section. Didactic analysis is performed for a topic in a course for which certain goals and contents have been defined in its global curriculum design. We should thus imagine that, as teachers, we have just finished the treatment of one topic (e.g., the linear function) and are going to start a new one (e.g., the quadratic function), as is indicated in the global curricular design of the course. The cycle begins with the teacher determining the students' current comprehension of the notions necessary to tackle the new topic, the contents that are to be studied and the learning objectives to be achieved. That is, the teacher should determine, from the perspective of the students' learning, the starting point (what the students know before starting the cycle) and the end point (what the teacher hopes that the students will know after the learning experience during a lesson).

## 2.2. Subject Matter Analysis

Subject matter analysis is the procedure by which the teacher can identify, organise and select the meanings of a concept or mathematical structure within the school mathematics content. The procedure is performed by attending to three dimensions: systems of representation, conceptual structure and phenomenology.

### *Systems of Representation*

Following one of the traditions of the literature in mathematics education, I will use the expression "systems of representation" to refer to the systems of signs by which a concept is designated. The importance of the systems of representation in

subject matter analysis lies in the fact that: (a) systems of representation organise the symbols by means of which mathematical concepts are presented; (b) different systems of representation contribute different meanings to each concept; and, therefore, (c) the same concept admits of and requires various complementary systems of representation. I use the definition given by Kaput (1992), in which a system of representation is “a system of rules (i) for identifying or creating characters, (ii) for operating on them and (iii) for determining relations among them (especially equivalence relations)” (p. 523).

Given that the same concept or mathematical structure can be represented in different systems of representation, it is possible to group and characterise the operations that can be performed on them into four categories:

1. *Creation and presentation of signs or expressions.* This operation enables us to determine valid and invalid expressions ( $(x)f = 3x^2 + 2$  is an example of an invalid expression in the symbolic system of representation for functions).
2. *Invariant syntactical transformations.* These are the transformations of one sign into another, within the same system of representation, in which the mathematical object designated by those signs does not change. Examples would be the procedures for completing squares, expansion and factorization that are shown in Figure 92.
3. *Variant syntactical transformations.* These are transformations of one sign into another, within the same system of representation, in which the mathematical object designated changes. This is the case, for example, of the horizontal and vertical translations shown in Figure 92.

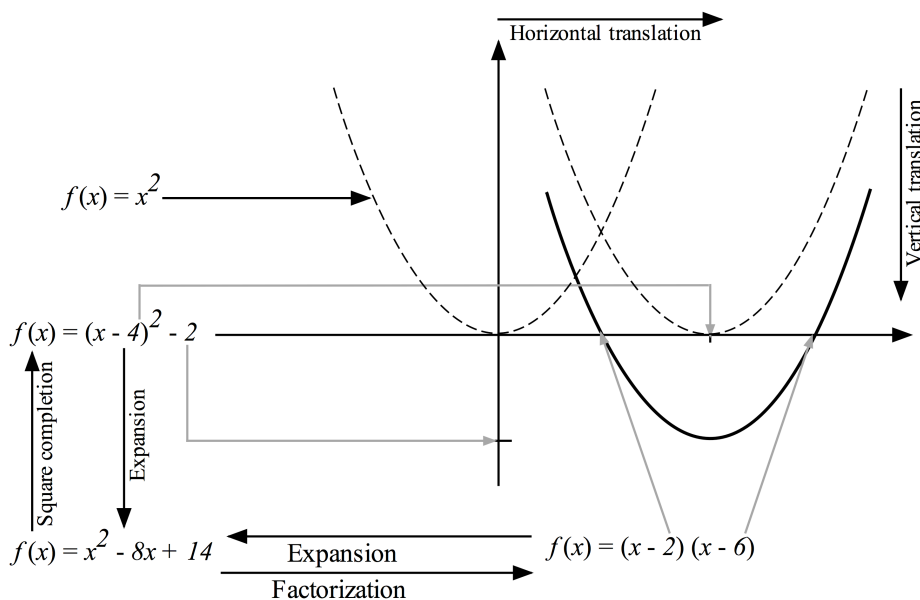

Figure 92. Operations in systems of representation

4. *Translation between systems of representation.* This operation refers to the procedure by which the relation is established between two signs that designate the same object but that belong to different systems of representation, for example, the relations between the parameters of the symbolic forms of the quadratic function and its graphic representation in a parabola in Figure 92.

#### *Conceptual Structure*

Systems of representation enable us to appreciate the complexity of the system of meanings of a mathematical concept. This complexity has its origin in the structural character of mathematical concepts: each concept configures a mathematical structure and forms part of other mathematical structures.

I will use the expression “conceptual structure” to refer to three aspects of every concept of the school mathematics content:

1. *Interrelated mathematical structures.* I will assume that every mathematical concept is related to at least two mathematical structures:
  - ◆ the mathematical structure that the concept configures and
  - ◆ the mathematical structures of which it forms part.
2. *Conceptual relations.* I will emphasise the relations that are established between the concept and
  - ◆ the concepts of the mathematical structure that this concept configures (e.g., the relation between the quadratic function and the quadratic equation),
  - ◆ the objects that are specific cases of this concept (e.g.,  $f(x) = 3x^2 - 4$  as a specific case of the quadratic functions of the form  $f(x) = ax^2 + c$ ), and
  - ◆ the concepts that belong to the mathematical structure of which the concept forms part (e.g., the relation between the quadratic function and continuous functions).
3. *Relations of representations.* Exploring the meanings of a concept requires systems of representation, since with them it is possible to identify the ways in which the concept is presented. On taking into account the systems of representation, we can point out the relations that arise from operations in the systems of representation: invariant syntactical transformations, translation between systems of representation and variant syntactical transformations.

When the teacher explores the conceptual structure of a concept in school mathematics, he should take into account three kinds of “elements” and two groups of relations between these elements. The elements are:

- ◆ the *objects*, as specific cases of a concept, forming its extension;
- ◆ the *concepts*, as predicates that are saturated by the objects and, in turn, form mathematical structures; and
- ◆ the *mathematical structures*, which are shaped by concepts.

On the other hand, the relations described in points 2 and 3 above can be grouped into two categories, which I call *vertical relations* and *horizontal relations*. Vertical relations refer to relations between the three kinds of elements: object  $\rightarrow$  concept  $\rightarrow$  mathematical structure. Horizontal relations refer to the relations between



signs in their different systems of representation (relations between representations).

I propose that the teacher use conceptual maps as a tool for gathering, organising, representing and sharing the information corresponding to the meanings of a mathematical concept. From the perspective of the mathematical content, in a conceptual map we can identify different kinds of connections that correspond partially to the vertical and horizontal relations I described above:

- ◆ connections that establish relations between different elements of the mathematical structure (for example, between the different symbolic forms and their parameters),
- ◆ connections that associate different representations of the same element (for example, the parameters of the multiplicative form and the roots of the parabola),
- ◆ connections that associate the transformations of one element into another within one system of representation (for example, the procedure of factorization for transforming the standard symbolic form into the multiplicative symbolic form), and
- ◆ connections that show the relation between categories of phenomena and the substructures with which it is possible to organise them (for example, the relation between the properties of the focus of the parabola and the phenomena of optics that use these properties—not shown in the figure).

### *Phenomenology*

I will use the term phenomenology, as a dimension of the meaning of a concept, to refer to the phenomena that give meaning to the concept. The concept acquires meaning with respect to the corresponding phenomena when the phenomena are linked to situations that the concept can describe or to questions that the concept allows us to ask. The same substructure can be related to diverse phenomena. We can therefore establish a relation between substructures and phenomena in which we assign to each phenomenon the substructure that serves as its model. We can establish pairs (Substructure<sub>*i*</sub>, Phenomenon<sub>*j*</sub>), in which Substructure<sub>*i*</sub> is a model of Phenomenon<sub>*j*</sub>. Figure 93 shows a diagram of these relationships.

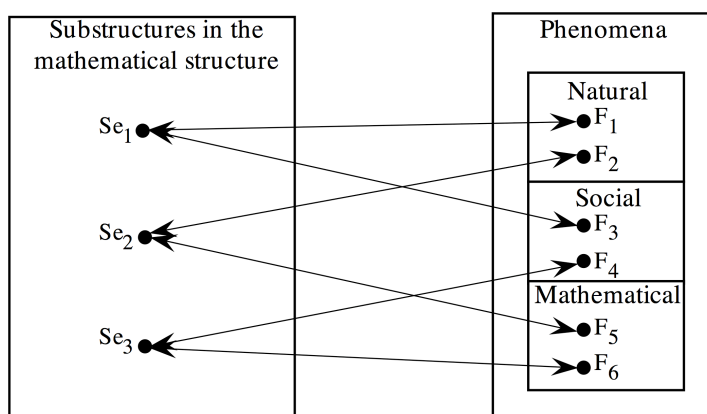

Figure 93. Phenomenological analysis

Thus, the phenomenological analysis of a mathematical structure involves the identification of:

1. the substructures corresponding to this structure,
2. the phenomena organised by each of these and
3. the relation between substructures and phenomena.

In this way, we can establish an equivalence relation in which each class of equivalence, represented by a given substructure organises all the phenomena of which it is a model. I use the expression *mathematical model* to designate the triad (substructure, phenomenon, relationship) in which the substructure is a model of the phenomenon according to a relationship. This relationship identifies those structural characteristics of the phenomenon (or of a situation or question related to the phenomenon) that are relevant from the mathematical perspective and at the same time are related to elements and properties of the mathematical structure in one or more systems of representation (see Figure 94).

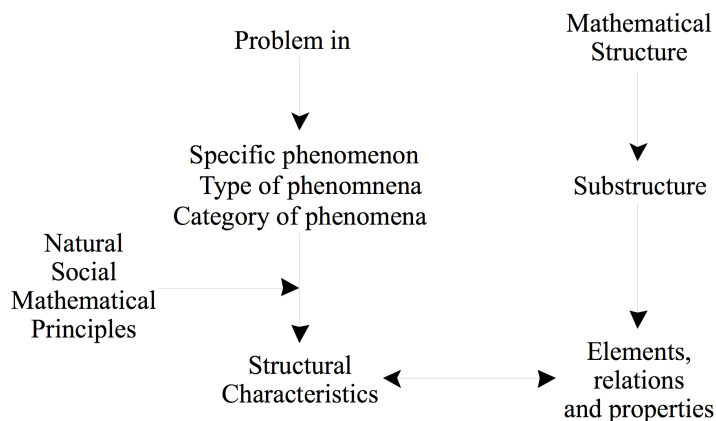

Figure 94. Phenomenological analysis and models

### 2.3. Cognitive Analysis

In cognitive analysis, “the teacher describes his hypotheses about how the students can progress in the construction of their knowledge of the mathematical structure when they face the tasks that compose the teaching and learning activities” (Gómez, 2002b, p. 271). To do this, the teacher must take into account his perception of the students’ understanding at the end of the previous cycle of didactic analysis, the goals that have been proposed for the next cycle, the content to be studied, and the context, among other issues. Cognitive analysis is an *a priori* analysis. With it, the teacher tries to foresee the students’ actions in the phase of the cycle in which the teaching and learning activities designed are brought into play. These hypotheses should be grounded in a description of the cognitive aspects related directly to the mathematical structure to be worked on with these activities.

I adapt the notion of *hypothetical learning trajectory* (Simon, 1995a) to the initial training of teachers of secondary school mathematics to propose the two procedures by which the future teacher can perform cognitive analysis. The first,

which I call *Table of Capacities-Competences*, through which the capacities are organised in terms of competences, enables us to describe and characterise the students' knowledge and mathematical thinking before and after the lesson. The second, based on the notion of *learning path*, is a procedure that uses the results of the first to enable the teacher to describe his hypotheses about the ways learning can develop between these two points. The cognitive meanings of school mathematics are based on three notions: capacities, competencies and difficulties.

Following the ideas that ground the notion of hypothetical learning trajectory (which I do not develop in this summary<sup>162</sup>) and taking into account the conditions in which initial training is performed, I propose a procedure to describe the students' progress based on the identification, description and relation of five elements:

1. the capacities that the students have before the lesson;
2. the capacities that the teacher hopes the students will develop from instruction and that configure the learning objectives;
3. the tasks that form the instruction;
4. the difficulties that the students may encounter in tackling these tasks; and
5. the hypotheses about the paths by which learning can develop.

I start from the notion of *capacity*. In the context of school mathematics, I use this term to refer to the action of a student with respect to a certain kind of task (for example, the problems of transforming a symbolic form of the quadratic function—the standard—into another—the canonical). I will argue that an individual has developed a certain capacity when he can complete tasks that require it.

The first two points of the procedure that I suggest require the future teacher to organise information on: (a) what the students are capable of doing before instruction and (b) what he expects them to be able to do after instruction. Lupiáñez, Rico, Gómez and Marín (2005) have developed a procedure for organising this information based on the notion of competence. This notion enables us to establish a link between planning on a local level (of some specific activities in a particular topic) and the global curricular design (of a course). For example, we can perform the analysis based on the seven competences proposed in the PISA study (OCDE, 2004).

The information that emerges from subject matter analysis should allow the teacher to identify those *foci* on which he will work. The capacities are identified and organised within these specific foci. The procedure is performed with the help of a table in which the competences are recorded in the columns and the capacities in the rows. The table enables the teacher to determine (decide) which capacities can contribute to which competences. For each focus, the teacher can calculate the degree to which the capacities included in the focus contribute to each of the competences.

The table of Capacities-Competences is a good tool for describing and characterising the starting and end points that determine the extremes of the paths by

---

<sup>162</sup> See the issue of *Mathematics Thinking and Learning* devoted to this topic (Clements y Sarama, 2004).

which learning can develop when students confront the activities that the teacher proposes to them. The information to produce it should come from subject matter analysis (the end point) and performance analysis (the starting point). The core of the information in this table is the list of the capacities that are included in each of the foci chosen.

In what follows, I present an example of the procedures involved in cognitive analysis. Let us suppose that the teacher has decided that he wants to work on a question that, in his experience or as a result of the information that comes from subject matter analysis, is important within the topic of the quadratic function. The purpose is to develop the capacities necessary for the students to solve problems involving the graphic meaning of the parameters of the symbolic forms of the quadratic function (see Figure 92).

Subject matter analysis provides most of the information needed to identify the capacities to be developed. In Figure 92, I have included some of the symbolic and graphic procedures that can be involved in the analysis. This detailed analysis shows that bringing the graphic meaning of the parameters of the quadratic function into play should involve knowing and using the procedures to transform one symbolic form into another, the symbolic and graphic procedures that establish the relation between the parameters in the canonical form, and the graphic transformations that are possible from the standard symbolic form.

In Table 46, I have identified some of the capacities implicit in this problem.

<i>Perform, communicate and justify symbolic transformation procedures</i>		<i>Identify, show and justify graphical elements</i>	
C1	Square completion	C8	Vertex coordinates
C2	Expansion	C9	Y-axis intersections
C3	Factorization	C10	X-axis intersections
		C11	Focus coordinates
		C12	Directrix equation
		C13	Symmetry axis equation
<i>Identify, show and justify symbolic elements</i>		<i>Perform, communicate and justify graphical transformation procedures</i>	
C4	Canonical form (a, h, k)	C14	Horizontal translation
C5	Focus form (p, h, k)	C15	Vertical translation
C6	Standard form (a, b, c)		
C7	Multiplicative form (a, $r_1$ , $r_2$ )	C16	Vertical scaling

Table 46. Capacities involved in using the graphical meaning of the parameters of the symbolic forms

One *learning path of a task* is a sequence of capacities that the students can bring into play to solve it. The learning paths of a task can be represented by a diagram in which the capacities that correspond to the learning objective are grouped, and the sequence of linked capacities are depicted. Figure 95 shows one learning path for task  $T_1$ , “Given that 2 and 6 are the intersections with the X axis of a parabola with vertical scaling 1, find the coordinates of the vertex”: determine the intersections with the X axis as a graphic element (C10), determine that these intersections correspond to the values of  $r_1$  and  $r_2$  in the multiplicative form of the quad-

atic function (C7), use the expansion procedure (C2) to obtain the standard form and determine it (C6), use the procedure of completing squares (C1) to obtain the canonical form and identify and determine its parameters  $h$  and  $k$  (C4), and establish the values of these parameters as the coordinates of the vertex in the graphic representation (C8).

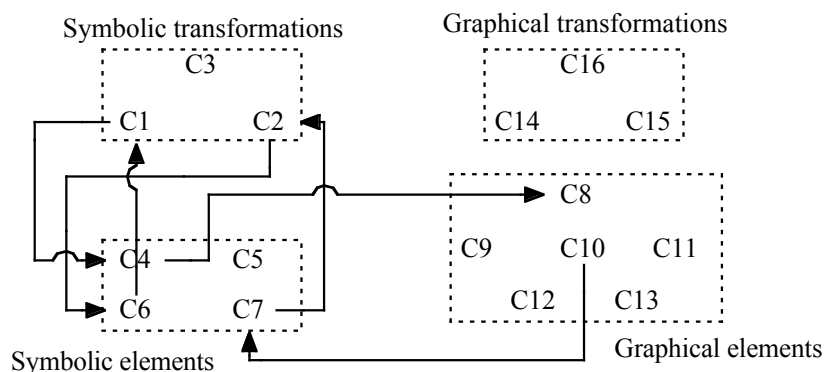

Figure 95. Learning path for task  $T_1$

The learning path for the task  $T_1$  that I present in Figure 95 informs the teacher of an *ideal* sequence of capacities that the students could bring into play to tackle the task. I say “ideal” because it is the sequence that arises from the conditions that the task imposes and the core of content that corresponds to the learning objective. From this ideal perspective, it is possible to speak of learning paths that correspond to a learning objective. To do this, the teacher can define all the tasks (or kinds of tasks) that characterise the objective, in the sense that the teacher considers that an individual has achieved the objective when he is capable of performing these tasks<sup>163</sup>. The learning paths of an objective are thus those that correspond to these tasks. A learning path is more than the capacities that compose it: it is the sequence of capacities that enable the completion of certain kinds of tasks.

When characterising a learning objective in terms of its learning paths, the teacher should take into account his knowledge of the students’ errors and difficulties. The teacher can then include this information in analysis of the learning paths for an objective. The enumeration and description of difficulties makes sense only when the teacher has identified and characterised the capacities that correspond to the core of the content related to the learning objective for which he wishes to produce a plan. Analysis of the difficulties indicates the key questions that must be taken into account in this process. They are sequences of capacities of the network of learning paths to which the teacher should give special emphasis.

Which paths students follow will depend on the tasks given to them. Describing the capacities and the possible learning paths enables the teacher to make con-

<sup>163</sup> I refer here to *non-routine* tasks for which students do not know pre-established procedures before instruction. Therefore, in the context of a specific lesson, the tasks that characterise an objective are, from the perspective of the students, different from the tasks that characterise capacities. The latter are routine tasks.

jectures about these paths and, in so doing, revise the tasks that can be proposed in designing them. In initial teacher training, the tasks will not be put into practice, and the process is therefore hypothetical.

#### 2.4. Instruction Analysis

The difference between cognitive analysis and instruction analysis is analytic: these two analyses depend on each other. In what follows, I will use the term *task* to refer to the instructions that the teacher gives the students; and I will refer to the *activities* of the students and the teacher that arise as a consequence of a task. In the two previous points, there are several implicit issues that should be made explicit:

- ◆ when assigning a task, the teacher has a purpose with respect to the students' learning, and that purpose can be articulated in terms of competences;
- ◆ when tackling a task, the students have a purpose (to complete it);
- ◆ the activities of the students and the teacher are composed of actions that seek to achieve the corresponding purposes;
- ◆ when performing these actions, both students and teacher bring into play a collection of capacities (that contribute to the development of the students' competences);
- ◆ the teacher's planning should include not only the analysis and selection of tasks, but also the forecasting of the possible actions the students may take when tackling a task and the capacities that they can bring into play to perform them.

I illustrate these relations visually in Figure 96, that shows the close relation between the notion of task and the notions of capacity and competence on which I based cognitive analysis.

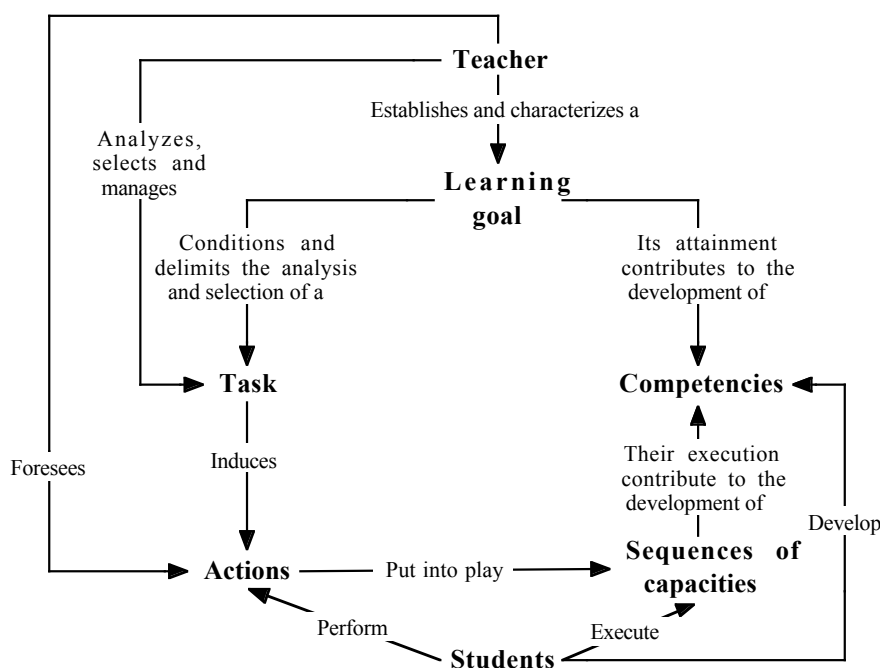

Figure 96. Task, capacities and competences

My focus is task analysis as a resource for achieving learning objectives. In this sense, the central criterion for classifying a task is its relation to the competences from which the teacher establishes the learning objectives and to the capacities that contribute to these competences. Therefore, rather than speaking of classification of tasks, I will speak of analysis and evaluation of tasks.

The model in Figure 96 shows the foundations of this purpose. Task analysis stems from the characterisation of the learning objective in terms of its contribution to the competences and its learning paths and should be a procedure that permits:

1. the identification of the capacities (and the possible links between them) that can be brought into play when the students tackle the task;
2. the construction of the diagram of learning paths that students can follow when they tackle the task;
3. the identification of the competences to which these capacities, with the task in question, can contribute and to what extent; and
4. the evaluation of the relevance of the task on the basis of this information.

Until now, this section has suggested a procedure that enables us to analyse and evaluate a task already designed. But how should we choose, design or adapt tasks? The tasks to which I refer are not routine tasks. They are what the literature refers to as “problems” and to the corresponding process of problem solving.

This leads me to underline the modelling of phenomena in the selection of tasks. In the framework of subject matter analysis, I described the notion of a

model as a one-to-one relation between elements and properties of a substructure of the mathematical structure and structural characteristics of social, natural and mathematical phenomena, and established their relation to phenomenological analysis. When students tackle a task, they are expected to bring into play the several relations between the mathematical structure and phenomena: in the modeling process and in the skills, reasoning processes and strategies that they should develop to identify the mathematical model that corresponds to a phenomenon (or a problem that refers to phenomenon); in the expression of this phenomenon or problem in terms of one or more systems of representation in order to solve the problem or interpret the phenomenon within these systems of representation; in the translation of the solution or the interpretation in terms of the phenomenon; and in the verification of this solution or interpretation. The teacher should thus perform two procedures when analysing and designing a task: phenomenological analysis, as the procedure that enables him to establish the relation between phenomena (and the problems that refer to them) and the mathematical structure; and simplification of the phenomenon or problem, that is, the transformation that the teacher should make of the problem from the real world into a text of the kind usually known as a word problem (Ortíz, 2000, p. 15).

The universe of tasks available can be expanded if the teacher takes into account the materials and resources available and the way these materials and resources enable the design of mathematical experiences complementary to those that can be proposed with paper and pencil. The materials and resources can transform the strategies that teacher and students use to represent the concepts and conceptual structures that form part of the mathematical structure (Gómez, 1997). When introducing the resource and using it in the design of tasks, the teacher can lead the students to bring into play capacities that would not emerge if the resource were not available. It is in this sense that the resources (and, in particular, technology) enable students to have new “mathematical experiences.” However, this situation does not affect the procedure of task analysis proposed in this section. The teacher will have to formulate conjectures about the students’ actions, the capacities that they will bring into play to perform them and the competences to which the capacities contribute (see Figure 96). Both the table of Capacities-Competences and the diagram of learning paths will change. Therefore, the relevance of using a resource in a task will be a function of its contribution to the learning objectives and of comparing this contribution to the result of the analysis of alternative tasks.

### 2.5. Performance Analysis

The purpose of performance analysis is to produce information that enables the teacher to determine the students’ current understanding, the contents to discuss in the classroom and the learning objectives that should be sought. In the first phase, the teacher can compare his predictions of what was going to happen in the classroom to what really happened. To do this, he can:

- ◆ establish to what extent the learning objectives were achieved, by identifying which capacities were brought into play and to what extent these capacities contributed to the competences considered relevant;



- ◆ review whether the tasks brought into play those capacities with which the teacher predicted that the students could have difficulties, whether these difficulties occurred (the students committed errors when bringing these capacities to bear) and whether some progress was achieved in overcoming these difficulties;
- ◆ identify the capacities that were brought into play and those that were not; and
- ◆ recognise the capacities, difficulties and strategies not foreseen yet shown in practice.

In summary, the teacher can produce the table of Capacities-Competences and the learning paths that are deduced from the students' action and compare them with those he predicted. The information gained from this analysis is relevant in a second phase of performance analysis to:

- ◆ review the relevance of the tasks used in the classroom;
- ◆ produce the table of Capacities-Competences for the new cycle;
- ◆ express, in possible learning paths, the teacher's conjectures on how the students' learning can be developed; and
- ◆ design, analyse and choose the tasks that shape the teaching and learning activities.

### 3. DIDACTIC KNOWLEDGE

In this section, I tackle the second question:

*¿What should be the knowledge, capacities and attitudes of a teacher who acts effectively and efficiently?*

The research literature on the teacher's knowledge in general and the mathematics teacher's knowledge in particular is extensive and varied. Different responses to this question (or related questions) have been formulated. The notion of pedagogical content knowledge proposed by Shulman (1986) has been one of the most important contributions to thinking on this topic. However, the general character of Shulman's original proposal does not allow us to explore the problem of the mathematics teacher's knowledge in detail. Most of the taxonomies of the teacher's knowledge are based on or use this idea and divide into separate compartments knowledge that in practice is brought into play in an integrated way. I will establish the meaning that I give to the expression "didactic knowledge" here and specify some of its characteristics. I maintain that reflecting on the teacher's knowledge should start from a functional view, in which the teacher's knowledge is a result of the analysis and description of the activities that he should perform to plan, manage and evaluate the lesson. Thus, the problem of the teacher's knowledge should be considered rather as the integration of knowledge, abilities and attitudes for action. This approach gives rise to the notion of the teacher's professional competences, an notion that has acquired great importance recently with the creation of an integrated higher education area in Europe. However, the proposals concerning the mathematics teacher's competences are currently lists of generic and specific competences in which it is not possible to identify either the relation between them or their function in the mathematics teacher's performance. I sug-

gest that, in using didactic analysis as a reference for the teacher's performance, it is possible to determine systematically and to organise in a structured way the capacities that contribute to the mathematics teacher's competences. I develop this notion with respect to the planning competence of the mathematics teacher.

### 3.1. Pedagogical Content Knowledge: a Powerful Notion

Until the early eighties, it was more or less generally accepted that the teacher's knowledge could be characterised by two independent and complementary components: knowledge of the discipline (content) and knowledge of general pedagogical issues. While criticising this view, Shulman (1987) produced a wider classification of the teacher's knowledge, which has been preserved with some changes by most researchers. This classification includes seven categories of the teacher's knowledge: thematic content, pedagogical content, other areas, curriculum, learners, educational goals, and general pedagogy (p. 8). Classifications like those of Shulman and Bromme (1994) necessarily imply a separation (at least analytical) of the teacher's different kinds of knowledge.

The meaning of the notion of pedagogical content knowledge has not evolved in a relevant way in the research on mathematical education in particular or in education in general over the last decade and a half. With some exceptions (e.g., Ball et al., 2005; Geddis y Wood, 1997; Morine-Dershimer y Kent, 2001), most of the studies that mention the notion continue to use it with the general meaning proposed by Shulman, as the knowledge needed to transform a particular content for teaching (Kinach, 2002, p. 53). Shulman's concern focused on the gap between the academic and disciplinary knowledge that the teacher can have of a specific topic and the form this knowledge should take in order to be transmitted in the classroom. But if we adopt a constructivist stance toward learning, the problem is not to produce a *discourse* to transmit knowledge but to design and manage some *activities* through which the students can construct their knowledge and the teacher can achieve the learning objectives that have been imposed. Therefore, it is necessary to extend the idea of transformation of a content to be transmitted. *The product of the transformation is not in itself content, but some activities.* But the design and management of these teaching and learning activities requires the identification, organisation and selection of the reference meanings of the concept to be taught in order to design, put into practice and evaluate the corresponding teaching and learning activities. As I showed in the previous section, this analysis—didactic analysis—is subject to some procedures and tools and is conditioned both by the teacher's beliefs and goals and by the characteristics of the social, educational, institutional and classroom contexts. In other words, when we speak of an "efficient teacher" [as do Cooney (1994) and others] or of "pedagogically powerful forms" (as does Shulman), we cannot think, as Carlsen (2001) suggests, of pre-established, static, neutral knowledge. Rather, we are speaking of *an integration of knowledge, abilities, and attitudes for action.* In our case, we are speaking of the teacher's competences for planning didactic units.

### 3.2. Didactic Knowledge in the Initial Training of High School Mathematics Teachers

I will use the expression *didactic knowledge* to refer to the knowledge and skills that are necessary to perform a didactic analysis of a mathematical topic. Didactic analysis is composed of a set of procedures that enable the teacher to analyse a specific mathematical structure from various perspectives (content, cognition, instruction, and performance). These procedures are grounded in some notions, the curriculum organisers, which arise from the discipline of Mathematics Education. For example, the procedure for performing the subject matter analysis of a mathematical structure is based on the curriculum organisers that I have identified as systems of representation, conceptual structure, and phenomenology. In the literature on Mathematics Education, we find a variety of possible meanings for the notions (curriculum organisers) that are brought into play in didactic analysis. I identify this knowledge as *disciplinary didactic reference knowledge*.

For the purpose of designing the course Mathematics Education in High School, we, as designers and trainers, have interpreted the disciplinary didactic reference knowledge, and we have chosen some particular meanings for each of the curriculum organisers. This is the *didactic reference knowledge for the course*, that is, the combination of knowledge and skills that we, as designers of this training plan, have taken as an option within the disciplinary didactic reference knowledge and that we hope that future teachers will interpret and construct as one of the results of their training.

When participating in an initial training plan (in particular, the course Mathematics Education in High School), future teachers (and groups of future teachers) interpret the didactic reference knowledge and construct knowledge (individual or of the group). *This is the didactic knowledge of the future teacher or group of future teachers*. It is knowledge in permanent evolution and, in fact, my empirical interest in this research project focuses on describing, characterising and explaining (in part) the processes by which groups of future teachers develop their didactic knowledge. I will thus refer to the *meaning that a future teacher or group of future teachers has (or develops) for a curriculum organiser*. In this research project, I focus my attention on the development of didactic knowledge of groups of future teachers on the curriculum organisers of the subject matter analysis.

The reference meaning of each curriculum organiser can be considered by attending to three different but related issues. These are the theoretical, technical and practical meaning of each curriculum organiser. The *theoretical meaning*<sup>164</sup> of a curriculum organiser refers to the option that, as trainers, we have taken to be the meaning of the curriculum organiser within the range of possible meanings that exist in the literature on Mathematics Education. This theoretical meaning supports a combination of ideal strategies of analysis of a mathematical concept that configure the *technical meaning* of each curriculum organiser. These technical meanings, although based on the theoretical meanings, go beyond them to indicate the character of analytic tool that each of the notions acquires.

The analysis of a mathematical structure by means of each curriculum organiser has a practical purpose: the information that arises from these analyses should

---

<sup>164</sup> I use this form, instead of “theoretical reference meaning for the course”, for ease of reading.

ground the planning we expect the groups of future teachers to perform. I use *practical meaning* of a curriculum organiser to refer to the set of strategies and techniques needed to use the information that arises from the analysis of the mathematical structure with this curriculum organiser in the other analyses that make up the didactic analysis and the design of the didactic unit.

I understand the didactic knowledge of a group of future teachers as the combination of knowledge and abilities that they use to tackle the analysis of a mathematical structure with the purpose of producing and justifying a lesson plan. From this perspective, the didactic knowledge of a group of future teachers is formed around a structured combination of capacities that characterise their planning competence.

### 3.3. Didactic Analysis and the Capacities and Competences of the Mathematics Teacher

The meaning of the notion of competence and of its implications for competence-based education has evolved over time. Most recent definitions of this notion have common traits:

*Competence involves the combination of attributes (knowledge, capabilities, skills, attitudes) structured into competencies which enable an individual or group to perform a role or set of tasks to an appropriate level or grade of quality or achievement (that is, an appropriate standard) in a particular type of situation, and thus make the individual or the group competent in that role... (Preston y Walker, 1993, p. 118, italics in the original)*

In the European context of higher education, the notion of competence has acquired importance through the Tuning project (González y Wagenaar, 2003). This project focuses on characterising generic and specific competences for those graduating from the first and second cycles of university education. In this framework, in the context of the definition of competences for the Bachelor's degree in mathematics in Spain, the Spanish Subcommission of the ICMI established some general and specific competences for the initial training of high school mathematics teachers during the Itermat Seminar (Recio, 2004) (Rico, 2004c, pp. 8-9).

I explore the description of the competences of the mathematics teacher from an analytic perspective. I will use the description of didactic analysis to identify the *capacities* that can contribute to the development of some of the mathematics teacher's competences. I will list and organise these capacities according to the four analyses that compose didactic analysis. These are the capacities that I consider necessary to plan, put into practice and evaluate a didactic unit on a specific mathematical topic. In subject matter analysis, the procedures that compose didactic analysis indicate that, for the three dimensions of the meaning of a concept, the teacher should be able to:

- ◆ obtain the information necessary to allow him to identify the meanings of the concept;
- ◆ organise this information in a way that will be useful for planning a lesson;

- ◆ select from this information the meanings that he considers relevant for instruction, taking into account the conditions of the social, educational, and institutional contexts; and
- ◆ choose the reference meanings, taking into account the conditions of the classroom context (which arise from the information obtained from cognitive analysis).

Taking into account the procedures that compose didactic analysis, it is possible to develop in detail the basic capacities that emerge from each analysis. For example, the first two capacities of subject matter analysis refer to the identification and organisation of the meanings of a mathematical concept. If we consider the dimensions of systems of representation and the conceptual structure of these meanings, then to perform these procedures the teacher should be able to do the following for the corresponding concept:

1. identify its elements (objects, concepts and mathematical structures),
2. determine the different representations of these elements and
3. establish the relations between the elements and their representations.

If we develop the third capacity into greater depth, we see that it implies that the teacher should be able to establish the relations:

- ◆ between the concept and the concepts of the mathematical structure that this concept configures,
- ◆ between the concept and the objects that are specific cases of this concept,
- ◆ between the concept and the concepts that belong to the mathematical structure of which the concept forms a part,
- ◆ between pairs of signs that designate the same object or concept, within the same system of representation (invariant syntactical transformations),
- ◆ between pairs of signs that designate the same object or concept belonging to different systems of representation (translation between systems of representation) and
- ◆ between pairs of signs that designate two different objects or concepts within the same system of representation (variant syntactical transformations).

In the example I have just presented, we can see the structure of the capacities that contribute to the planning competence of a mathematics teacher. It is possible to identify some basic capacities that contribute to this competence and to structure them according to the analyses that compose didactic analysis. I have only analysed one of the basic capacities corresponding to subject matter analysis, as an example of how we could characterise in detail the mathematics teacher's competences. All of the capacities and the relations between them make up what I call *didactic knowledge*: the knowledge and skills (theoretical, as well as technical and practical) needed to perform didactic analysis of a mathematical topic. In reality, "the blending of content and pedagogy into an understanding how particular topics, problems or issues are organised, represented, and adapted to the diverse interests and abilities of learners, and presented for instruction" (Shulman, 1987 p. 8) that lie at the core of the notion of pedagogical content knowledge is more than a blend: it is a complex structure of knowledge and capacities that emerges when,

considering the specificity of a topic, we explore the problems of designing, putting into practice and evaluating didactic units.

## 4. FUTURE TEACHERS' LEARNING

In this section, I present the conceptual framework for the empirical studies that compose the research project described in this document. To do this, I take a position on the learning of future teachers in the context of the development of the course. Based on this position, I specify the meaning for which I will use the key terms of these studies: meanings that the groups of future teachers construct, development of didactic knowledge, and states and factors of development, among others. To identify the central notions and theories that give them meaning, I take into account both the general and specific goals of the empirical studies and the conditions under which they were made. I advance some aspects of the design of these studies in order to define the scope of the discussion.

The design of the course imposed conditions for the performance of the empirical studies. In this design, we sought to have the teachers develop competences for the design of didactic units. These competences had as a frame of reference didactic analysis and the notions that it organises. In particular, through subject matter analysis, the course sought to have the future teachers develop both knowledge of the notions of systems of representation, conceptual structure and phenomenology and the capacities needed to bring this knowledge into play. They were to obtain and organise information on the specific concept and use this information to produce and justify the design of a didactic unit. The future teachers worked in groups, and the course promoted interaction among them. The information available for the empirical studies emerged naturally from the normal development of the course (the productions and performances<sup>165</sup> of the future teachers when they tackled and performed the tasks required of them).

### 4.1. Future Teachers' Learning

Different theories of learning do not necessarily contradict each other. Learning is a multidimensional phenomenon. Each theory has its foci of interest for research, with which it illuminates different aspects of this phenomenon (Anderson et al., 2000). For example, different views of the nature of knowledge imply different approaches to learning (Putnam y Borko, 2000). However, in the case of the initial training of high school mathematics teachers, we should recognize that the teachers neither work nor learn alone. Teaching and learning to teach are social practices that require collaboration among peers (Secada y Adajian, 1997). The initial training of mathematics teachers is a complex social practice. The socio-cultural approach attends to this complexity (Adler, 1998; Lerman, 2001, p. 45). Research on the training of teachers from this perspective enables us to explore and characterise aspects of the process of teachers' change that traditional psychological perspectives do not allow us to see (Stein y Brown, 1997, p. 155), as these perspec-

---

<sup>165</sup> I use the term "production" to refer to the work handed in by the groups of future teachers and "performance" to refer to the actions performed by their members in the classroom.

tives tend to study the development process of individual teachers in highly structured contexts.

When taking into account the previous arguments and stating the goals of the empirical studies and the information gathered for them, I have chosen Wenger's social theory of learning (1998) as the conceptual foundation for the learning of future teachers. This theory views learning as a social phenomenon that forms part of the experience of participating socially in the world. The idea of participation refers to "a more encompassing process of being active participants in the *practices* of social communities and constructing *identities* in relation to these communities" (p. 4, italics in the original). Learning as social participation is based on four notions (p. 5):

- ◆ *meaning*, as our changing ability (individual and collective) to experience our life and the world as meaningful;
- ◆ *practice*, as our resources, plans and historically and socially shared perspectives that can support the mutual commitment to action;
- ◆ *community*, as the social configurations in which our enterprises are defined as worthwhile and our participation is recognisable as competence; and
- ◆ *identity*, as expression of how learning changes who we are and creates personal histories of becoming in the context of our communities.

The notion of meaning is located in a process of negotiation of meaning that emerges from the interaction between two other processes: participation and reification. Through participation, we establish relationships with other people, define our way of forming part of communities in which we commit ourselves to certain enterprises, and develop our identity. Through reification, we project our meanings and perceive them as existing in the world, such that we manage to materialise our experience in concrete things.

The notion of community is based on three ideas:

- ◆ *mutual commitment*, as the commitment to actions whose meaning is negotiated and that generate relationships between people;
- ◆ a *joint enterprise*, which is negotiated collectively and continually and which generates mutual responsibility and determines what is valued, discussed and shown and
- ◆ a *shared repertoire*, which includes the resources for negotiation of meaning, the discourse that enables us to make meaningful statements about the world and the styles for expressing forms of membership and identity as members.

Practice is an unstable, emerging structure, and learning in practice implies a mutual commitment to the search for an enterprise with a shared repertoire. Therefore, learning emerges to the extent that:

- ◆ different kinds of mutual commitment evolve;
- ◆ the enterprise is understood and refined; and
- ◆ shared repertoire is developed.

Mutual commitment generates relationships between people and connects them in diverse and complex ways. The development of practice involves maintaining sufficient mutual commitment in the search for the enterprise, together with sharing

of meaningful learning. The evolution of different kinds of mutual commitment is characterised by:

- ◆ how the environment influences it (what helps and what hinders),
- ◆ how identities are defined,
- ◆ how relationships are developed, and
- ◆ how meaning is generated, negotiated, and reified.

The joint enterprise of a practice is negotiated collectively and permanently and creates relationships of mutual responsibility between the participants who determine what is valued, discussed, justified, and expressed. The pattern of mutual responsibility becomes an integral part of practice. The process of understanding and fine-tuning the enterprise is characterised by:

- ◆ the role of external conditions,
- ◆ the characteristics of the discourse (what is discussed, expressed, valued), and
- ◆ the definition of the enterprise and the responsibilities.

The joint pursuit of the enterprise creates resources for the negotiation of meaning. These resources are the shared repertoire. They include routines, tools, symbols, actions or concepts that the community has created or adopted and converted into part of its practice. The repertoire “includes the discourse by which the members create meaningful statements about the world, as well as the styles by which they express their forms of membership and their identities as members” (p. 83). The repertoire reflects the history of mutual responsibility and remains inherently ambiguous. Both history and ambiguity contribute to the creation of meaning, but they can also generate obstacles. The development of the shared repertoire is characterised by:

- ◆ the styles of expression and work routines and
- ◆ the resources for negotiation of meaning.

#### **4.2. Two Communities of Practice: Partial, Theoretical, Technical and Practical Meanings**

In the context of the course Mathematics Education in High School and based on the previous discussion, I conceptualise the following two work environments as communities of practice:

- ◆ the *community of practice of the classroom*, in which the productions of the groups of future teachers are discussed and critiqued and in which the meanings brought into play are negotiated and established (on many occasions, without reference to a specific topic); and
- ◆ the *community of practice of each group of future teachers*, in which the meanings are negotiated and established (on most occasions as specific to the group’s topic) by bringing them into play when developing the productions that the group will present to its colleagues and to the trainers.

My interest in this research project focuses on the learning processes that take place in the communities of practice of each of the groups. Given the work methodology of the course, the results of these learning processes are made explicit in the community of practice of the classroom, when each group periodically and systematically makes its presentations to the others. Therefore, the classroom’s



community of practice conditions the activities of the groups' communities of practice: for each presentation, each group must reach consensus about the task in question. This consensus is made explicit in the information contained on the transparencies that the group uses to make its presentation and in the performance of the group's members in class.

I consider, therefore, that the information contained in the transparencies and the classroom performance of the group's members are expressions of the meanings that this group has constructed so far. I use the term *partial meanings* to refer to these meanings. I call them "partial" because I want to emphasise that the meanings that one group has constructed at a given moment in the course are always open to improvement. They are the result of what the group has learned up to that point, as a result of a continuous and dynamic process of negotiating meanings in the group's community of practice. In other words, for each presentation, each group has achieved a certain development of its shared repertoire, and its productions (transparencies and performance) are expressions of this shared repertoire.

Examining and describing the development of didactic knowledge of the groups of future teachers requires characterising their partial meanings as these meanings are expressed in their productions and performances. Let us remember that each curriculum organiser in the subject matter analysis (for example, the notion of systems of representation) has different meanings. I characterise these meanings in terms of the actions, capacities and knowledge that we expect the future teacher to develop in tackling the analysis of a specific mathematical topic. In the context of the course, we hope that, for each of the curriculum organisers of didactic analysis and for a specific mathematical concept, the future teacher:

1. will know the meaning of the curriculum organiser;
2. will obtain and organise information on the meanings of the concept in terms of the curriculum organiser;
3. will use the information obtained to perform the other analyses of the didactic analysis; and
4. will use the information from all of the analyses for the design of the didactic unit.

These activities performed by the teacher correspond to the theoretical (1), technical (2) and practical (3 and 4) meanings of the curriculum organisers that compose the didactic analysis and in turn configure three kinds of knowledge that the future teacher will have. In this context, *theoretical knowledge* is declarative and involves the capacity to describe the notion in the abstract. I call *technical* the knowledge and capacities to analyse a mathematical concept in terms of a given curriculum organiser. For example, identifying the different representations of a concept forms part of technical knowledge. Finally, in this context, *practical knowledge* involves the capacities required to use technical information in an orchestrated way with a practical purpose (e.g., the planning of a didactic unit).

The relation between the activities the future teacher is expected to perform, the meanings of the curriculum organisers in didactic analysis and the kinds of knowledge involved show the complexity of didactic knowledge and of the initial

training of high school mathematics teachers. Didactic knowledge, such as the knowledge brought into play and developed in performing didactic analysis, is *knowledge for action*, as I characterised it when I described it in terms of competences. Development of this knowledge requires future teachers to be able to transform the notions that make up the didactic analysis into instruments. The development of the didactic knowledge of future teachers is based on an interplay between theory and practice that can be characterised by adapting the theory of instrumental genesis (Rabardel, 2003; Rabardel y Bourmaud, 2003; Vérillon, 2000): This is achieved by using the curriculum organiser (the instrument) as a mediator between future teachers and the concept on which they are working, a mediator that they construct and about which they develop meanings concerning both the notion and the concept. The idea of instrumental genesis arises from the argument that an artefact becomes an instrument to the extent that three processes take place:

1. *Instrumentalisation*, as the process in which the subject transforms and adapts the artefact to his needs and circumstances (Rabardel y Bourmaud, 2003, p. 673).
2. *Instrumentation*, as the process by which techniques are developed (p. 673). These are abilities to apply the tool to perform significant tasks (Kaptelinin, 2003, p. 834) that are transformed into techniques (Artigue, 2002, p. 250). A technique is an amalgam of reasoning and routine procedures that enable the completion of a task (p. 248).
3. *Orchestrated integration*, by which the tool is integrated with other artefacts (Kaptelinin, 2003, p. 834).

These ideas allow me to conceptualise the main aspects of the activity of a group of future teachers in a phase of the methodological cycle of didactic analysis, when they tackle the task of analysing their concept with the help of a curriculum organiser or when they use the information that emerges from this analysis to perform other analyses or design the didactic unit.

When performing these tasks, the group develops processes of instrumentalisation, instrumentation and orchestrated integration. That is, they transform and adapt the meaning that they assign to the curriculum organiser (instrument), develop plans for applying the tool either to obtain information about the meanings of the concept (object) or to use this information in other analyses, and integrate the use of a specific instrument (e.g., the systems of representation) into other instruments in the design of the didactic unit. *It is through using the instrument (curriculum organiser) as mediator among the group of future teachers (subject) and the concept on which they are working (object) that the group constructs and develops meanings about both the curriculum organiser and the concept.* This activity, which involves the generation of techniques, transforms the group's practice.

Instrumental genesis takes place in this process of performing tasks: the artefact (the curriculum organiser, in its theoretical conception) is transformed into an instrument to the extent that the group of future teachers develops plans to complete the tasks with the help of the instrument. And it is in this process of instrumental genesis that the group negotiates meanings (of the curriculum organiser, of

the object and of the plans) that are brought into play in the activity, reified in the shared repertoire and manifested in their productions and performance in the classroom. As a result, the idea of instrumental genesis allows me—for the specific context of this research project—to specify and conceptualise the general process of negotiation of meaning proposed by Wenger into a more specific process that characterises the activities that the groups of future teachers perform outside class.

### **4.3. Development of Didactic Knowledge and Development Factors**

In the context of Wenger's social theory of learning (1998), the idea of development acquires a significance of which I will develop one specific aspect: the development of the shared repertoire. By specifying the notion of development of didactic knowledge in the development of the shared repertoire of each group of future teachers, I can relate the ideas of development and meaning in the same conceptual framework. Following Wenger, I use the expression "shared repertoire" as the reification of the processes of negotiation of meaning that takes place when groups of future teachers, as communities of practice, tackle the tasks of the course. It is in this process that the shared repertoire is *developed*. Given that each time that the groups of future teachers make a presentation in class, they must arrive at a consensus on what they are going to propose, the processes of negotiation of meaning are made specific (reified) systematically and periodically. This reification is expressed in the information contained in the transparencies used by the groups of future teachers to make their presentations and in the presentation by the members of the group supporting their proposals.

I tackle the exploration of the learning of groups of future teachers, from the perspective of the development of their didactic knowledge, from two approaches:

1. the description and characterisation of the productions and performance of the groups of future teachers in their work within the community of learning in the classroom and
2. the description and characterisation of the processes of negotiating meaning that take place in the community of learning of one of the groups of future teachers.

In the first approach, I focus my interest on the productions of the groups of future teachers and on some aspects of the processes of negotiation of meaning that emerge from the presentation of these productions in class. My purpose is to describe and characterise what results from the processes of negotiation of meaning within each group of future teachers. In particular, I am interested in studying how the productions and performance of each group change (evolve) over time, as a reflection of the evolution of the meanings brought into play by each group in developing each production and thus as an expression of the development of their shared repertoire.

In the second approach, I examine in greater depth, for the case a specific group of future teachers, the processes of negotiation of meaning that give rise to these productions. In this second approach, I analyse the constitution and development of the group's community of practice, following the guidelines of Wenger's social theory of learning.

I conjecture that it is possible to identify patterns in two aspects of the productions of the groups of future teachers. On the one hand, it is natural to think that the differences (with respect to a curriculum organiser) in the productions of the groups are the result of a limited number of the groups' partial meanings. Therefore, I hope to identify patterns (categories) that organise those partial meanings. These patterns in the partial meanings should be expressed in a limited number of *attributes* of the productions. These attributes characterise the bringing into play of these meanings in the analysis and description of a mathematical structure.

The second kind of pattern has to do with the process of change in the groups' productions. I believe that, just as it is possible on many occasions to identify states that characterise the cognitive development of the individual, it is also possible (but not for the same reasons) to think that the development of didactic knowledge of groups of future teachers can be characterised in terms of certain *states of development*. Each state of development would be determined by patterns in the evolution of the partial meanings of the groups of future teachers. If it is possible to identify these states of development, my interest will focus on exploring how changes in the productions of the groups of future teachers can be both representative of and represented by these states. In this way, I would succeed in establishing a preliminary approach to the study of the development of the didactic knowledge of the groups of future teachers.

The notion of state of development, as a representation of patterns in the partial meanings that the groups of future teachers bring into play in developing their productions and interacting in the classroom, enables me to be more specific about the idea of the difficulty and progress of a group of future teachers. I will say that the productions or performance of a group reveal a *difficulty* with respect to a curriculum organiser when successive productions by the group do not evolve but rather remain in the same state. I will speak of the *progress and advance* of the productions of a group when they move from early states to more advanced ones. In terms of the meanings of the groups of future teachers, the difficulties are revealed in partial meanings that persist in spite of the efforts of instruction to change them. Progress shows the reorganisation of these partial meanings into others closer to the reference meanings promoted by instruction.

I am inspired by the idea of "quality of information" developed in the discipline of management of organisations to reformulate and organise the attributes of the quality of the information contained in the transparencies of groups of future teachers and expressed in their class presentations in three dimensions, which I call *development factors*: variety, organisation and role. The factor *variety* includes the idea that, for each curriculum organiser of subject matter analysis, the description of a mathematical structure can be made with a larger or smaller quantity of information, depth or complexity<sup>166</sup>. The factor *organisation* indicates how, within a production, the information gathered is organised for one or more curriculum organisers of the subject matter analysis. Finally, the third organising fac-

---

<sup>166</sup> Given that the number of levels of a conceptual map not only represent variety but also indicate its structural complexity, I call this factor for the specific case of the structural concept, *complexity*. The factor called organisation of the conceptual structure explores another aspect of this structural complexity.

tor of the attributes of a production is the putting into practice of the information gathered for a given curriculum organiser. I call this factor *role*, since it seeks to reflect the role that each curriculum organiser of the subject matter analysis plays in other aspects of the didactic analysis.

To summarise, the attributes that reflect the meanings that a group has brought into play in a production for each curriculum organiser of the subject matter analysis can be organised into three factors: variety (or complexity), organisation and role. These factors are related, as shown in Figure 97.

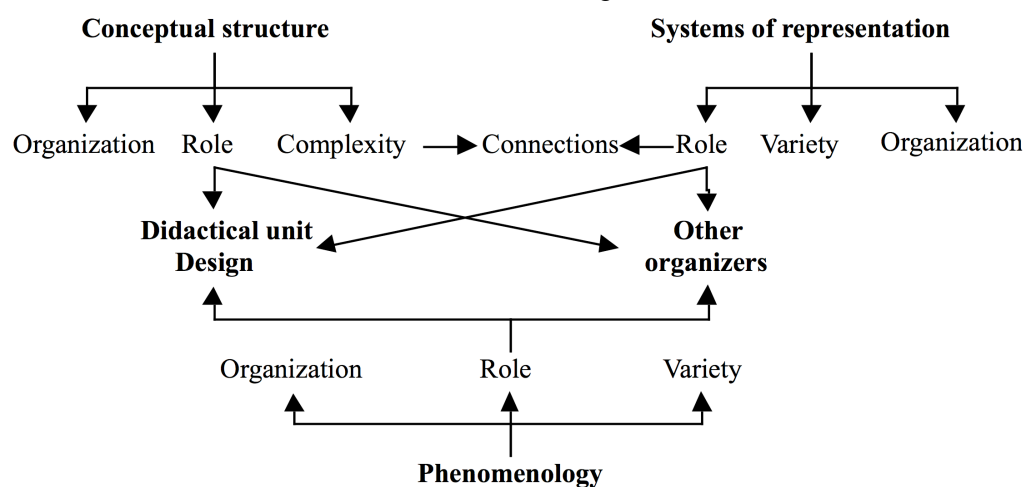

Figure 97. Development factors of didactic knowledge

The notions of partial meaning and didactic knowledge refer to attributes that cannot be observed in the groups. To discuss these, it is necessary to refer to the productions and performance of the groups as expressions of these meanings and of this knowledge. To specify the relationship between these two aspects of the research problem, I establish links between the different elements described in this section (see Figure 98).

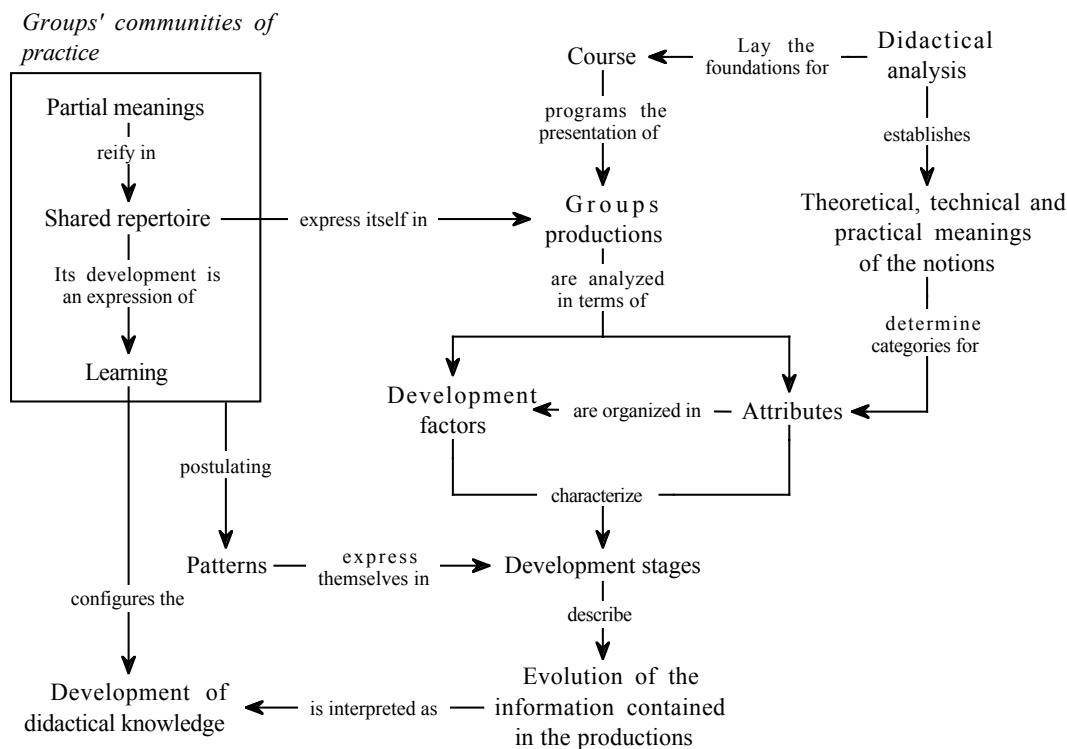

Figure 98. Learning, productions and development of didactic knowledge

I began by defining my theoretical approach on the future teachers' learning. This is a socio-cultural view of learning through which each group is conceptualised as a community of practice in which its members negotiate meanings. These meanings, which I have called partial given that they are continually subject to improvement, reify in the shared repertoire of each group. The productions and performance of a group in completing a task are the expression of the development of their shared repertoire up to that point. The design of the course foresees the periodic presentation of these productions. Didactic analysis, as a conceptualisation of the teaching of high school mathematics, grounds the design of the course and establishes the theoretical, technical and practical meanings of the curriculum organisers of the subject matter analysis. These meanings determine the categories used to analyse the productions in terms of certain attributes. These attributes are organised into development factors. They postulate regularities in the development of the shared repertoire of the different groups and assume, therefore, the existence of the patterns expressed in some states of development. It is conjectured that these changes in the productions of the groups of future teachers can be both representative of and represented by these states. If they can be characterised, these states describe a process of evolution in the information contained in the groups' productions. This process can then be interpreted in terms of the development of the didactic knowledge of the groups of future teachers, as an expression of the development of their shared repertoire.

## 5. DESIGN OF THE COURSE<sup>167</sup>

My purpose in this section is to show the role of my proposal on didactic analysis and didactic knowledge in grounding and conceptualising the course and to describe it as the context in which the empirical studies were performed.

### 5.1. The Course

I am describing the course delivered in 2000, with specific attention to three aspects: the context, its grounding and its curricular design.

#### *Context*

The educational policy in effect when this research project was undertaken proceeded from the Reformed University Law of 1983 (Boletín Oficial del Estado, 1983), known as “the LRU” and the Law of the General Arrangement of the Education System of 1990 (Boletín Oficial del Estado, 1990), known as “the LOGSE”. The LOGSE establishes the basic conditions for achieving the status of a teacher: a Bachelor’s degree or that of engineer or architect plus the Certificate of Pedagogical Aptitude (CAP). Universities offer graduate study programmes that grant this certificate. In the case of the University of Granada, those who take the Methodology Specialisation, which I will describe next, receive the CAP. Those who satisfy these two basic conditions and wish to pursue a position as high school mathematics teacher must pass the “oposiciones” (competitive national examinations).

In 2000, the University of Granada had a study programme for initial training of high school mathematics teachers. This programme formed part of the Bachelor’s degree in mathematics at the university. The Bachelor’s degree offered three specialisations: Pure Mathematics, Statistics and Methodology. The students chose one of these at the beginning of the fourth year. The first specialisation sought to train mathematics researchers, the second mathematicians with the capacity to perform in the production and service sectors and the third, high school mathematics teachers. The study programme was based on the Methodology Specialisation.

At the University of Granada, and at the Spanish university in general, the academic culture can be summarised as an evaluation plan based on very few exams, in which the students “risk” passing or not passing each subject, and a teaching plan in which there are no textbooks and where the professor presents, in the fashion of chair professor, his own content. As a result, the students develop a study plan that focuses on taking notes during class, organising them at home and studying them, in most cases only a short time before exams.

---

<sup>167</sup> From now on, to simplify, I will speak of “the course”. The course is a living being, constantly evolving. Its curricular design in the academic year 2000-01 was the product of this process of continuous transformation. I use the present tense to facilitate reading, although this section describes the curricular design of the course during the academic year 2000-01.

Most future teachers who participate in the course believe that they have solid training in mathematics. Their main concern when they begin the training plan for teachers has to do with managing the class, the issue in teaching that generates the greatest unease. They expect the plan to provide them with solutions to what they perceive to be the practical problems that they will encounter in the classroom (Gómez et al., 2002). Two thirds of the future teachers have teaching experience prior to the training plan, through work in private classes or in tutoring services for high school students. This teaching experience gives rise to “didactic intuitions” that often ground their performance when they tackle the tasks performed in class (Gómez, 2001a).

### *Foundations*

The notion of didactic analysis is central to the foundation of the second block of the course. In emphasising the role of didactic analysis in the teacher’s activities and the initial training of teachers, we take sides: we start from a particular position on how students learn mathematics in the classroom and propose an ideal vision of how teaching should develop. This establishes one of the two anchors of our conception of the training of high school mathematics teachers: to contribute to the development of the competences and capacities necessary to perform didactic analysis. Our view of the learning of future teachers provides the second anchor for our conception of the initial training of high school mathematics teachers, on which the design of the course is based. We have taken a social constructivist position.

The characterisation of the procedures that compose didactic analysis and the reference meanings of the notions involved in these procedures enable me to identify and structure the capacities needed for the high school mathematics teacher’s planning competence and thus to specify the didactic knowledge that we wish future teachers to develop during the course. This functional view of the initial training of teachers grounds the goals and contents of the second block of the course. The methodological and evaluation plans in the design are based on our position with respect to the future teachers’ learning.

## **5.2. Course Design**

To describe the design of the course, I follow a curricular plan and describe briefly its aims, goals, contents, methodology and evaluation plan.

### *Aims and Goals*

The aim of the course is to contribute to beginning the training of the future mathematics teacher through mathematics education. In the course, we seek to contribute to the training of the future teacher in two dimensions: the beginning of his participation in communities of practice of mathematics educators and the development of the knowledge and capacities necessary for the planning of didactic units. In considering that the course, as a training plan in the processes of planning didactic units, is also a community of practice, we wish the future teachers to develop their capacity for participation in this community by constructing the knowledge and capacities needed to perform didactic analysis. The knowledge and capacities are specified in the social construction of meanings of the notion of curriculum, the foundations of school mathematics and the curriculum organisers.



*Contents*

The contents of the course are organised according to the outline in Figure 99. The course begins with analysis of and reflection on the history of mathematics and of mathematical education in Spain, which serves as the context in which to discuss the antecedents of Spain's mathematics curriculum. The notion of curriculum is the foundation supporting the rest of the contents. We discuss the goals of mathematics education and reflect on the levels and dimensions of the curriculum. Using this conceptual reference, we analyse some Spanish and international curriculum projects, reflect on the antecedents of the mathematics curriculum in Spain, and study the general organisation, levels of specificity and contents of the high school mathematics curriculum currently in effect.

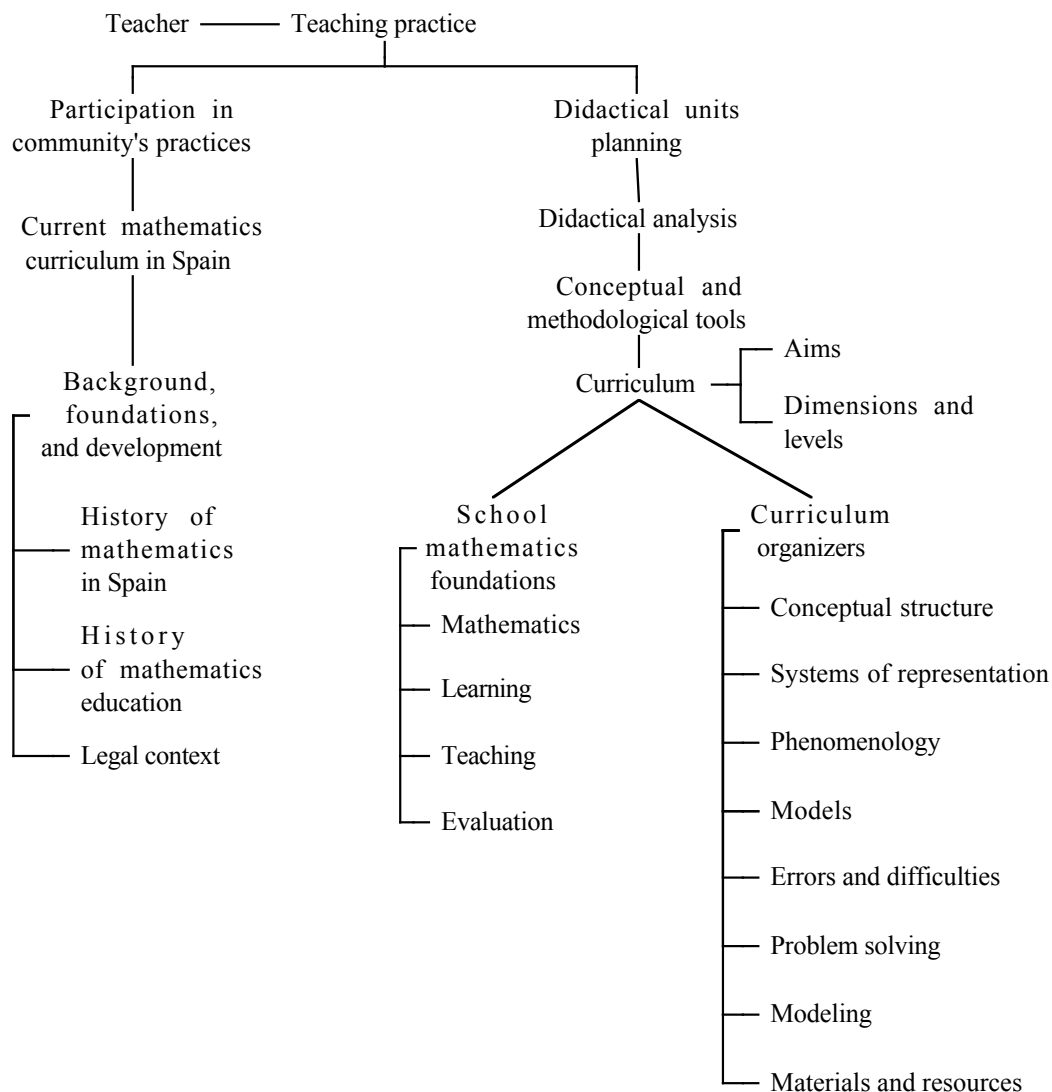

Figure 99. Content structure of the course

Didactic analysis organises the treatment of the curriculum organisers. We develop a general theoretical analysis of each of the curriculum organisers but also study the ways that these notions acquire technical and practical meaning when they are used to analyse specific mathematical structures. The course thus has a specific mathematical content that is shown in the mathematical structures for which the didactic analysis is performed.

#### *Methodology*

In the course, we use different methodological plans. I will now describe the plan used systematically in the simulation of the process of planning a didactic unit.

Each group of future teachers chooses a mathematical topic on which to perform the didactic analysis and design a didactic unit. The plan is cyclical. Each cycle corresponds to a curriculum organiser. The sequential order in which the curriculum organisers are treated follows the plan shown in Figure 99.

The cycle starts from the discussion that ended the previous cycle. In general, this discussion (for example, of systems of representation) leads to the introduction of a new curriculum organiser (for example, the notion of phenomenology). From this introduction, we propose an in-class exercise that consists of using this notion for a predetermined mathematical structure or the mathematical structure on which each group is working. The groups present their proposals and discuss possible meanings of the curriculum organiser in its practical application. Then, the trainers present an example of how the notion can be used for a specific mathematical structure (different from those assigned to the groups). For the next class, the students are to apply this curriculum organiser (and those considered so far) to a mathematical structure. In the next session, each group presents the results of its work to the rest of the class. Classmates and trainers discuss and critique each presentation. Finally, the trainers moderate a discussion in which we seek to formulate questions and activities that tackle the errors and difficulties we found in the presentations. On some occasions, the trainers suggest aspects of the reference meaning of the curriculum organiser being used. The end of the cycle has two parts. First, the trainers use the previous discussion to motivate the introduction of a new curriculum organiser. Second, one of the trainers reviews each of the productions and produces a document with his comments and suggestions. The future teachers receive this document at the next session.

### *Evaluation*

When we look at the classroom as a community of practice and consider learning as progress in participation in this community, evaluation is expressed as one curricular component that is constantly present in all aspects of the training process. When it is accepted that there is a common problem to be solved and that there are conceptual tools and methodologies for tackling it, and when the future teachers share their productions with the rest of the class and negotiate the social meanings that govern discourse in the classroom, individuals and groups can recognise the strengths and deficiencies of their contributions. The classroom discourse revolves around the meanings that individuals and groups mobilise to solve the problems. Thus, these meanings are constantly being evaluated, discussed and critiqued. This evaluation takes place in the two communities of practice. As trainers, we guide the discourse in the classroom to emphasise the achievements and deficiencies of the contributions proposed, taking into account the disciplinary knowledge that serves as a reference for didactic knowledge. On the other hand, for each written production of the future teachers (document or transparency for a presentation), we produce a document in which we formulate our comments, criticisms and suggestions.

The evaluation of the work of the future teachers is the result of the evaluation of all of their productions and of the trainers' appraisal of the way in which each future teacher progresses in his participation in the classroom's community

of practice. We pay special attention to the work and the final presentation in which each group presents and justifies the design of a didactic unit on its topic.

## 6. DEVELOPMENT OF THE COURSE

The purpose of this section is to describe the development of the course during the 2000-01 academic year. This was the period in which I gathered the information for the studies that compose the empirical dimension of this research project. The learning process of the groups of future teachers depended, as was to be expected, on the experiences gained during the academic year from having attended and performed activities that took place in the course. Therefore, the development of the course is central information for achieving the goals of this research project. But it is not possible (and makes no sense) to reproduce here each of the events that, a priori, might have had some effect on the learning of the future teachers. I will identify these events in the empirical studies that I present in subsequent sections. In this section, I will present a general view of the sequence in which we treated the contents and describe the class sessions in which we worked on didactic analysis. For this block of the course, I will also present an example of the productions of one of the groups of future teachers and of the comments made on these productions.

### 6.1. Organisation and Development of the Course

In the academic year 2000-01, 36 future teachers registered for the course, 25 women and 11 men. All were students pursuing the Bachelor's degree in Mathematics at the University of Granada and were in the fourth or fifth year of the Methodology Specialisation. During the first few weeks, the future teachers were organised into eight groups: five groups of five, two groups of four and one group of three members. These groups remained stable throughout the course. At the beginning of the second quarter, each group chose a mathematical topic for which it would develop a didactic analysis and produce the design of a didactic unit. The topics chosen were the following: graphs and functions, progressions, decimal numbers, probability, conic sections, the sphere, quadratic function and systems of linear equations.

The course syllabus was followed strictly, with delays of no more than one class hour. The plan of the modules that I presented in the previous section, and in which the curriculum organisers were studied in a similar way, was followed strictly in the development of the subject matter analysis (see Figure 101, below). In the other analyses of the didactic analysis, the plan was combined with presentations by the trainers on theories of learning, difficulties and errors, problem solving and evaluation.

### 6.2. Sessions on Subject Matter Analysis

The following describes briefly the class sessions on subject matter analysis.

### *Conceptual Structure*

The session began with a review of the topics covered in previous sessions. The trainer proposed an exercise through which he sought to explain to the future teachers his idea on the concept of derivative. The trainer observed the group work, answered questions and suggested organising the ideas that had emerged. The future teachers participated actively with different proposals. Various future teachers expressed their concern for teaching, but the trainer specified the mathematical aspects of the exercise. Interest was expressed in examining the relations of the concept of the derivative. One future teacher observed that, “everything must be related, because it has to do with the concept of derivative”. Another future teacher established the difference between the concept of derivative and its applications. This observation generated a discussion among several future teachers, in which several didactic and historical aspects of the concept were raised. The trainer insisted on the need to focus on the mathematical aspects of the concept and to try to organise the information obtained. At the end of the session, the trainer formulated the work to be done for the next session.

At the start of the next session, some future teachers commented on and raised questions about the idea of concept and conceptual structure. Several comments focused on the role of the definition as a means for “making a concept understood”. The trainer presented the future teachers with a proposal for a conceptual structure for the idea of derivative and suggested that they try to improve on the conceptual structures they had made for their topic. The groups of future teachers worked in class. In the second part of the session, they presented the result of their work. The notion of systems of representation as another curriculum organiser was identified. In the next hour of class, the groups of future teachers presented their proposals for the conceptual structure of their topic.

### *Conceptual Structure and Systems of Representation*

The notion of system of representation was introduced in the following session, based on the work that the future teachers had done in the previous session. The comments by the future teachers conveyed some of their difficulties with this notion: they did not see the systems of representation as a means of organising the conceptual structure and did not succeed in focusing their attention on the mathematical aspects of the concept: they continued to express their concern with didactic questions. However, one central idea emerged: they were representing the same object (concept), so the elements of different representations had to be related. At the end of the session, the trainer formulated the following task:

*Next week, we will continue with the topic of systems of representation. And the task due in a week...is to try to improve, detail, deepen the conceptual structure of each topic, trying to emphasise, trying to reflect on, the role that the systems of representation can play in describing the plan... Then what we want is to see how deep we can go...in trying to emphasise not only that there are a great number of elements, but trying to emphasise how these elements are related, how they are structured. One of the ways that we can have criteria for structuring them is by trying to see how the notion of systems of representation can contribute to this structure ... [42-B192]*

In the next two sessions, the groups of future teachers presented their work. On this occasion, it happened that each group received comments and critiques immediately after its presentation. This generated discussion and further explanation among the future teachers.

Figure 100 presents the transparency used by the group on quadratic function to make its presentation. The transparency is organised into three categories: symbolic, graphic and phenomenology. In the symbolic system of representation, we find the following categories: forms of expression, zeros of a function, vertices, concavity, convexity, axis of symmetry, domain, trajectory. The multiplicative symbolic form appears for the first time. In the graphic system of representation, the future teachers introduce the idea of cuádrics. In phenomenology, they develop in detail mathematical phenomena such as area and volume. They establish very clear external point-to-point connections, identifying the coordinates of points such as the vertex and the intersections with the x-axis. They also establish connections for vertical scaling, concavity and the axis of symmetry.

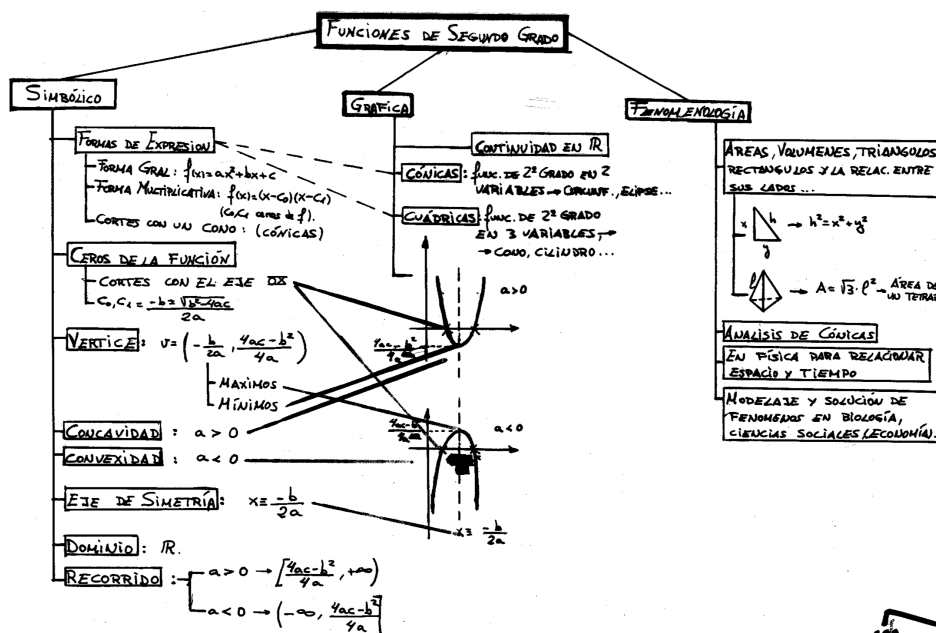

Figure 100. Conceptual structure and systems of representation of the quadratic function group

This version did not show very radical changes over the previous version. The most interesting issue was the appearance of a series of very clear external point-to-point connections, as well as the appearance of the multiplicative form within the symbolic system of representation. The mention of the numerical system disappeared (it was the table of values in the previous version). The internal connections within the symbolic system of representation were implicit (expressing some properties as a function of the parameters of the general form). The procedures for

symbolic treatment were still not present, with the exception of the use of the quadratic equation for relating the two symbolic forms presented. To summarise, the group kept the structure it used previously and described parts of it in greater detail.

The following text corresponds to some of the comments that, as trainer, I made on the presentation and the transparencies of the group on quadratic function just discussed.

*... What are the elements of each system of representation, and what are the properties? How are they related to each other?*

...

*In the case of the symbolic system of representation, it is interesting that the multiplicative form has appeared and that you have suggested a relation between this form and the general form by means of the quadratic equation. Are there more symbolic forms? If there are, how are they related to each other? What elements do they have, and what properties are emphasised in them? How are these elements and properties related to the elements and properties of other systems of representation, such as the geometric system of the Cartesian plane?*

#### *Systems of Representation and Phenomenological Analysis*

In the next two sessions, the trainer, basing his comments on the previous work of the groups of future teachers, specified the meaning of the notions of conceptual structure and system of representation and introduced the notion of phenomenology. Then and during the next two sessions, the groups of future teachers presented their work. This included improving the conceptual structure, taking into account systems of representation, and attempting a first phenomenological analysis of a topic.

#### *Phenomenology*

From the comments and discussion generated by the previous presentations, the trainer led the groups of future teachers to improve their work on the phenomenology of each topic. In the following session, they presented their work.

### **6.3. The Rest of the Sessions on Didactic Analysis**

The rest of the sessions of the course dealt with cognitive analysis and instruction analysis. The trainers introduced the notions of modelling, errors and difficulties and gave a presentation on theories of learning. The future teachers analysed their topic from this perspective. In the instruction analysis, they reflected on problem solving and discussed materials and resources. The groups of future teachers were asked to identify one difficulty related to their topic and to design an activity to tackle this difficulty. The trainers gave a presentation on evaluation, and the groups of future teachers designed and presented an evaluation activity for their topic. The last class sessions were devoted to the trainers' presentation of an example of didactic analysis and the design of a didactic unit on natural numbers. The final course activity was the presentation of the final projects of the different groups of future teachers.

## 7. DESIGN OF THE EMPIRICAL STUDIES

In this section, I will describe the design of the empirical studies with which I seek to tackle the fourth question: What characterises the learning processes of the future high school mathematics teachers who participate in this kind of initial training programme?

### 7.1. From a General Question to some Research Goals

In the previous sections, I specified this general question by defining the research context and describing the concepts and theories that will enable me to give meaning to the expression “characterise the learning processes of the future high school mathematics teachers”. I can now formulate some specific research questions:

1. What are the partial meanings, with respect to the notions of subject matter analysis that emerge in the development of didactic knowledge when groups of future teachers participate in the course?
2. How can we describe the evolution of these partial meanings in terms of states and factors of development?
3. How can we characterise the states of development, if they can be determined?
4. Is it possible to explain these states of development, and the associated partial meanings, in terms of what happens in the community of learning in the classroom and in the community of learning in one of the groups?

I can also describe the general goal of the research. It is to

*describe and characterise the development of the didactic knowledge of the groups of future teachers who participated in the course on Mathematics Education in High School in the academic year 2000-01 with respect to the notions that compose subject matter analysis.*

I describe this general objective more fully in the following specific objectives.

1. For each of the notions considered and for the relationships between them, to describe and characterise
  - ◆ the partial meanings that the groups of future teachers developed throughout the course and
  - ◆ the evolution of didactic knowledge of the groups of future teachers in terms of states and factors of development.
2. I also seek to
  - ◆ propose conjectures that will enable me to explain the evolution of didactic knowledge in the groups of future teachers, and
  - ◆ contrast some of these conjectures.

### 7.2. Methodology: Making Choices

This section describes the path that I, as designer, trainer, and researcher, followed over several years in my relation to the initial training of high school mathematical teachers in general and to one training programme in particular. I was not the



focus of the research, but its design and results tell about my beliefs, values and attitudes, as well as my performance as a trainer and researcher.

My beliefs and values are expressed first in the conceptual choices I have made and presented in the previous sections. These choices include the conceptualisation of the teaching of mathematics, a functional vision of the teacher's knowledge, a position on how this knowledge is constructed and developed, a proposal about how the initial training of high school mathematics teachers should be achieved and a detailed description of how the course developed.

Within the limits established in the conceptual framework just described, it is possible to think of multiple methodological strategies for tackling the research problem. The choice of methods was determined by two issues: ensuring that performing the research would affect the development of course as little as possible, and deciding to focus attention on the work and productions of the groups of future teachers, relegating the analysis of the performance and the productions of the future teachers as individuals to second place. These choices are shaped by my intention to investigate using the information that arose naturally from the course and my interest in exploring the processes of negotiation of meaning in a group of future teachers when they worked outside the classroom on tasks assigned for class.

This research is a case study: the case of the development of didactic knowledge of future teachers of a specific course at a specific time. Its purpose is to give a "proof of existence"; that is, to present evidence of a case in which a strategy (of training) produces certain results.

### 7.3. Information Sources

In the thematic block on didactic analysis, we used the cyclical work plan described in Figure 101.

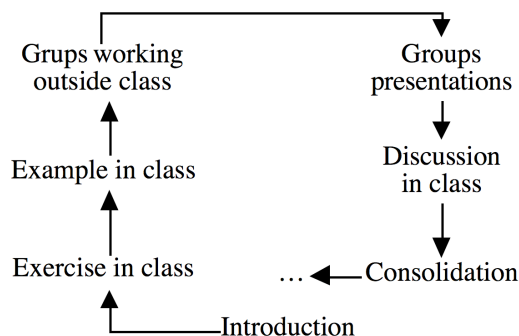

Figure 101. Cycle of methodological treatment of didactic analysis

This work plan gave rise to three kinds of information that I used in the empirical studies:

1. the information contained in the transparencies used by the groups of future teachers and by the trainers to give their class presentations,
2. the information contained in the transcriptions of the audio recordings of the class sessions and

3. the information contained in the final projects presented by the groups of future teachers.

I used two additional sources:

4. the transcriptions of the audio recordings of semi-structured interviews with the groups on conic sections and arithmetic and geometric progressions as they were finishing the didactic analysis and at the end of the course and
5. the transcriptions of the audio recordings of the work sessions outside the classroom by the group on quadratic function in the process of developing its presentations and the final project.

#### 7.4. Four Studies

To tackle the research problem and achieve the objectives, I organised the project into four studies. I identified each study by its main information source:

- ◆ analysis of the presentations
- ◆ analysis of the productions and performance of the groups of future teachers in the classroom and in the interviews with the two groups of future teachers,
- ◆ analysis of the final projects and
- ◆ analysis of the performance of the group on quadratic function in its work outside the classroom.

In what follows, I will call these studies *presentations*, *productions*, *final projects* and *group on quadratic function*, respectively. I will describe these studies in the following sections.

## 8. FOUR STATES OF THE DEVELOPMENT OF DIDACTIC KNOWLEDGE

This chapter presents a first attempt to characterise the development of didactic knowledge in the groups of future teachers who participated in the course. To do this, I use the information contained in the transparencies that they used to make their periodic presentations in class<sup>168</sup>. I used the notion of development factor to interpret the information contained in the transparencies in terms of the evolution of partial meanings that the groups of future teachers developed with respect to each of the curriculum organisers of subject matter analysis. This imposed some specific goals: (a) to identify the most representative attributes of the transparencies of the groups of future teachers; (b) to define some variables for analysis based on these attributes; (c) to verify that these variables follow stable patterns over time; (d) to identify and characterise some of the states of development from these variables; and (e) to describe and characterise the development of didactic knowledge from these states of development.

---

<sup>168</sup> For easier reading, I will often use the term “transparency” to refer to the information contained in these documents.

### **8.1. From 72 Transparencies to Four States of Development**

Although each group worked on a specific mathematical topic throughout the course, I was interested in producing a characterisation of the evolution of the partial meanings of the different groups of future teachers that would be independent of these topics. In other words, I was interested in comparing the progress of the different groups. How to codify the 72 transparencies to achieve these goals? One transparency from a group gave schematic information on this group's analysis of its topic. Each analysis used as a tool one or more of the curriculum organisers. My purpose was thus to define the combination of codification variables that I could use to characterise the attributes from the 72 transparencies. Since each transparency expressed the partial meanings of a group at a given moment, its codification should be based on the technical and practical meanings of the curriculum organisers.

For example, I decided to consider the following systems of representation: symbolic, graphic, numerical, geometric, figurative, verbal and others. For each variable, I established whether the corresponding system of representation appeared in the transparency. The process of identifying and defining the codification variables was cyclical. Starting from the technical and practical meanings of the curriculum organisers of the subject matter analysis, I produced a list of variables that I used to create a first codification of the 72 transparencies. Next, I clarified and extended the initial list, taking into account the development factors: organisation, complexity and role. With these criteria, I performed several codification cycles, trying with each cycle to fine-tune the choice and definition of the codification variables. I obtained a final list of 120 codification variables. The variables characterise the transparencies according to diverse criteria. For example, from the perspective of the development factor "complexity", I considered (among other things) the number of different kinds of phenomena and the number of substructures.

From these codification variables, I defined (again, through a cyclical process) 12 variables for analysis, taking into account what our experience as trainers indicated about how the groups of future teachers advance in their learning; the review and systematic analysis of transparencies and their codification; the technical and practical meanings of the curriculum organisers of the subject matter analysis; and the analysis of the development factors and their meaning. The development factors were the guiding thread in the process of transforming and summarising the basic data (which emerged from the codification variables) in the variables for analysis. The variables that emerged were the following: (a) number of levels of the conceptual map that describes the topic, (b) existence of the main ideas of the topic in the conceptual structure, (c) number of criteria for organisation of the conceptual structure, (d) consistent use of the organisation criteria, (e) number of connections, (f) number of systems of representation, (g) role of systems of representation as organisers of the conceptual structure, (h) number of contexts (mathematical, natural, social) to which the phenomena presented belong, (i) number of disciplines to which the phenomena presented belong, (j) number of substructures used to organise the phenomena, (k) role of the three curriculum organisers of the subject matter analysis in the use of the other curriculum

organisers and in the design of the didactic unit, and (l) consistency between the proposal of the conceptual structure and its use in other phases of the course.

The values of these variables were obtained from the values of the codification variables. In what follows, I will use the term *observation* to refer to the information contained in a transparency and to its interpretation in terms of the variables of analysis just presented. A first analysis of the observations allowed me to verify that they followed a pattern of evolution and to establish that these patterns could be characterised by four states of development. Once I had characterised all of the variables of analysis and decided on the number of states, the problem was to characterise these states in terms of combinations of values of these variables, such that the succession of states would be representative of an evolution and the observations would fit as much as possible the states to which they were assigned. The first step in this attempt focused on the formulation of a preliminary definition of the states that would be consistent with the conceptual framework (the technical and practical meaning of the curriculum organisers of the subject matter analysis) and with my experience as a trainer. For each variable, I identified four ranges of values, each range corresponding to one of the four states, successively. I imposed two conditions for the definition of the ranges: the union of the four ranges should be equal to the total range of the values that the variable could assume; and two successive ranges of a variable could share at most one value — unless the range is of the type  $[n, \infty)$ —. Table 47 shows the ranges I assigned to each of the variables and from which I defined the first version of the states.

	Variables	States			
		1	2	3	4
1	CE Complexity	[0, 0]	[1, 1]	[2, 2]	[3, $\infty$ )
2	Central notions	[0, 0]	[0, 0]	[1, 1]	[1, 1]
3	Organization criteria	[3, $\infty$ )	[2, 3]	[1, 2]	[0, 1]
4	Coherent use of criteria	[0, 0]	[0, 1]	[1, 1]	[1, 1]
5	Connections	[0, 0]	[1, 2]	[2, $\infty$ )	[3, $\infty$ )
6	RS variety	[0, 1]	[1, 2]	[2, $\infty$ )	[3, $\infty$ )
7	RS as organizers	[0, 1]	[2, 2]	[2, 3]	[3, 3]
8	Phenomena variety	[0, 1]	[1, 2]	[2, $\infty$ )	[2, $\infty$ )
9	Disciplines variety	[0, 1]	[1, 2]	[2, 3]	[3, $\infty$ )
10	Substructures variety	[0, 0]	[0, 1]	[1, 2]	[2, $\infty$ )
11	Role	[0, 0]	[0, 0]	[0, 5]	[6, $\infty$ )
12	CE coherence	[0, 0]	[0, 0]	[1, 1]	[1, $\infty$ )

Table 47. First definition of the states

To establish the development states, I used a procedure that I called *discrepancy analysis*, described as follows. The purpose is to obtain the definition of the states in terms of the variables that provides the best possible fit with the observations. When assigning observations to states, discrepancies appear. This occurs when, for at least one variable and one state, an observation assigned to that state assumes values that do not belong to the range established for this variable in this state. The problem is to obtain a definition of states that minimises the number of discrepancies, with an acceptable degree of discrimination between them.

This process of obtaining the definition of the states is cyclical. Each cycle is composed of two steps: assigning observations to states and changing the definition of the ranges of some of the variables for some of the states. In the first step, the assigning is done such that the state chosen for an observation is that which generates the lowest number of discrepancies. In the second step, the variables that generated a greater number of discrepancies are identified, as well as the states in which they generate these discrepancies. We then analyse the consequences of changing the definition of those states (and possibly of contiguous states) in terms of these variables. The change in ranges is governed by a twofold criterion: to reduce the number of discrepancies while maintaining an acceptable level of discrimination between states. Once the ranges of the variables that generate a larger number of discrepancies have been changed (in the states that generate them), it is necessary to review the assignment of observations to states. This begins a new cycle. The data from this study required three cycles. When I reviewed the definition of the states in terms of the variables the fourth time, I saw that the changes that enabled me to reduce discrepancies involved too significant a loss in the degree of discrimination. Therefore, I stopped the process at this point.

## 8.2. Four States of Development of Didactic Knowledge

I used the procedure that I have just described to analyse the observations. Table 48 presents the definition of the states that I obtained after three cycles of the procedure.

	Variables	States			
		1	2	3	4
1	CE Complexity	[0,0]	[1,2]	[2,∞)	[2,∞)
2	Central notions	[0,0]	[0,1]	[1,1]	[1,1]
3	Organization criteria	[3,∞)	[2,3]	[1,2]	[0,1]
4	Coherent use of criteria	[0,0]	[0,1]	[1,1]	[1,1]
5	Connections	[0,0]	[1,3]	[3,∞)	[3,∞)
6	RS variety	[0,1]	[1,∞)	[2,∞)	[3,∞)
7	RS as organizers	[0,1]	[1,2]	[2,3]	[3,3]
8	Phenomena variety	[0,1]	[1,2]	[2,∞)	[2,∞)
9	Disciplines variety	[0,1]	[1,∞)	[2,∞)	[3,∞)
10	Substructures variety	[0,0]	[0,1]	[1,∞)	[2,∞)
11	Role	[0,0]	[0,5]	[0,5]	[6,∞)
12	CE coherence	[0,0]	[0,0]	[0,0]	[1, ∞)

Table 48. Final definition of states

Table 49 presents the final assignment of observations to states. Each row represents a group of future teachers and their corresponding observations, organised chronologically. The observations corresponding, for example, to group 7 were then assigned successively to the following states: 2, 2, 3, 3, 3, 3, 4, 3 and 4.

Group	Observation								
	1	2	3	4	5	6	7	8	9
1	2	2	2	3	3	4	3	4	4
2	1	2	3	3	3	3	3	3	4
3	1	2	2	3	3	3	3	3	3
4	2	2	2	2	2	3	3	3	3
5	2	2	3	3	3	3	3	4	4
6	2	2	2	3	3	3	2	3	4
7	2	2	3	3	3	3	4	4	4
8	1	2	2	2	3	3	3	2	2

Table 49. Final assignment of observations to states

Finally, Table 50 presents the number of discrepancies by group and observation.

Group	Observation									Total
	1	2	3	4	5	6	7	8	9	
1 Functions and graphs	1	1	2	0	0	0	1	1	0	6
2 Progressions	3	3	0	0	1	1	1	2	2	13
3 Decimal numbers	1	2	2	2	1	1	1	0	1	11
4 Probability	3	0	2	1	2	1	1	1	5	16
5 Conics	3	1	2	0	1	1	3	2	3	16
6 Sphere	2	1	1	1	1	2	2	4	3	17
7 Second degree function	2	1	0	0	0	2	2	3	0	10
8 Systems of lineal equations	2	1	1	0	3	1	5	3	4	20
Total	17	10	10	4	9	9	16	16	18	109

Table 50. Number of discrepancies by group and observation

Because the definition of the variables and the corresponding observations did not satisfy the conditions of standard methods of grouping, such as cluster analysis, I developed the discrepancy analysis. However, the definition of the states that emerged from this analysis grouped the values of each variable in a maximum of four ranges. I used these ranges to define some new variables, such that for a given variable I assigned the value 1 to the first range, the value 2 to the second, and so on. With these new variables, I performed a cluster analysis of the observations and confirmed that the results were consistent with the result of the discrepancy analysis.

### 8.3. States of Development, Evolution and Progress of the Groups

The schema for codifying and analysing the information with which I obtained the results is based on a cyclical process that seeks to minimise discrepancies. The states of development that emerge from this process identify the combinations of values (or ranges of values) of the variables to which, as a whole, the observations are best adapted to a given task. These combinations of values of variables can thus be considered representative of the most significant states of development of didactic knowledge in the groups of future teachers. From the information in Ta-

ble 48, I can characterise these four states in terms of the curriculum organisers of the subject matter analysis and the development factors, as follows:

*State 1* is a basic state in which the conceptual structure lacks complexity, various criteria are used without consistency, at most one system of representation is used (without connections), and there is no variety in the phenomenological analysis. In Table 49, we see that only three groups have observations classified in this state. This suggests that it is a state that can be surpassed with the prior knowledge and didactic intuitions that the future teachers bring initially to the task.

*State 2* is a transition state. There is some complexity in the conceptual structure, and variety begins to appear in the systems of representation, although there is still no variety in the phenomenological analysis.

*State 3* shows an advance in all of the variables except those of role and consistency. The conceptual structure is complex, with an intermediate level of organisation. There is variety in the systems of representation and the number of connections. There is some variety in the phenomenological analysis.

*State 4* achieves full complexity in the phenomenological analysis, and we can see the consistent use of the information for the completion of tasks.

#### **8.4. A First Approach to the Development of Didactic Knowledge**

The characterisation of the states and assigning of the observations to them is the main result of this study. This result confirms my initial conjecture: that the didactic knowledge of the groups of future teachers evolves according to stable patterns. This is a gradual evolution that starts from a basic state possibly grounded in prior knowledge and didactic intuitions of the groups of future teachers. The development is consistent with the order in which the different notions are presented during instruction. However, there is a lag between the time the topics were presented and the time the partial meanings of the groups of future teachers materialise in the shared repertoire and are expressed in their productions. The notion of systems of representation, for example, is not consolidated at the time when this curriculum organiser was presented in class and the groups of future teachers were asked to analyse their topic from this perspective. This is only the first step.

The partial meanings of the groups of future teachers for this curriculum organiser undergo diverse transformations and are consolidated to the extent that subsequent tasks lead the groups of future teachers to bring their knowledge of this notion into play to solve other problems (for example, to perform the phenomenological analysis or design an evaluation activity). In terms of the theory of instrumental genesis, the artefact (the curriculum organiser) is transformed into an instrument to the extent that the groups of future teachers develop plans for completing the tasks with the help of the instrument. The process of instrumental genesis takes time: it requires that the groups of future teachers negotiate meanings (of the curriculum organiser, of their mathematical topic and of their techniques) that these partial meanings materialise (in different forms) on subsequent occasions when the groups present their productions in class. This process explains some of the differences between the observations and the pattern expected from the classification of the four states.

The groups progress in the development of their didactic knowledge at different rates. The step from state 2 to state 3 occurs at different moments (from the third observation for three groups, from the sixth for group 4). Two groups establish their productions in state 3 and, of the five groups that present productions classified in state 4, two achieve it as late as the last observation (the final project). One group regresses to state 2 in the last two productions.

These varied rhythms of progress and levels of advance can have different causes. The variety of the moments at which the move from state 2 to state 3 occurs may indicate some difficulty in bringing into play and developing the notions of systems of representation and phenomenology. However, all of the groups succeeded in overcoming this difficulty. The step from state 3 to state 4 is more complex. There are groups that do not achieve it and others that only achieve it in the final project.

There is a partial consistency between the rate of progress and the level of advance of the different groups and the total number of discrepancies they present. The groups with a higher rate of progress and level of advance (1 and 7) are also groups with a lower number of discrepancies. Two of the three groups with a greater number of discrepancies are the groups with a slower rate of progress and lower level of advance. This situation may confirm the idea that the discrepancies are a measure of the consistency with which the group advances in each of the dimensions of its didactic knowledge (the variables).

The analysis of the discrepancies of each variable sheds light on which notions presented most difficulties for the groups of future teachers. The notion of connections presented a high number of discrepancies with positive difference. In spite of the repeated efforts in instruction, the productions of the groups of future teachers have a level of connection lower than that expected. Something similar occurs, although to a lesser degree, with the notions of variety of phenomena, variety in systems of representation, complexity and systems of representation as an organiser of conceptual structure. These are the notions that present greater difficulties for the groups of future teachers.

### **8.5. Unresolved Questions**

The analysis of the results obtained answers in part one of the questions I formulated before, the question of how we can characterise the states of development, if these can be determined. At the same time, these results generate new questions that should be explored. The information contained in the transparencies expresses the partial meanings that the groups of future teachers had developed up to that point. These partial meanings are the reification of the processes of negotiating meaning that take place in the two communities of practice that I have identified: the community of practice in the classroom and the community of practice in each group. How can we characterise these partial meanings, and to what extent do they depend on the specific topics on which the different groups of future teachers worked? This is another of the questions I have formulated. To answer it, we must: (a) deepen our understanding of the meaning of the attributes and the variables that characterise the transparencies and establish the patterns in the partial meanings of the groups of future teachers, and (b) based on this, deepen our understanding of the states of development that characterise the evolution of the di-



didactic knowledge of the groups of future teachers. We must also formulate and contrast conjectures that explain: (a) the gradual and unsynchronised character of the evolution of didactic knowledge in the groups of future teachers; (b) the differences between the groups; and (c) the difficulties that the groups of future teachers must face with respect to some of the notions.

The attempt to answer these questions leads me to explore the complexity of didactic knowledge, the subject of the next two sections.

## 9. THE COMPLEXITY OF DIDACTIC KNOWLEDGE

This section presents the study in which I analyse the transparencies and class presentations of the future teachers and take into account the specificity of the information with respect to each group's topic. My purpose is to identify and characterise the partial meanings of the groups of future teachers concerning the notions of subject matter analysis and to describe the evolution of these meanings throughout the course. In other words, this section will tackle the question:

*¿How do we characterise the partial meanings that the groups of future teachers expressed in their transparencies and their class presentations, and how do these evolve over time?*

In what follows, I will describe the methodological plan that I used to perform this study. I will then present its results for each of the three curriculum organisers that compose the subject matter analysis. In the last sections, I will interpret these results in terms of the complexity of didactic knowledge.

### 9.1. Identification and Characterisation of the Partial Meanings

To perform this study, I used three sources of information: (a) the information proposed by the groups of future teachers in their transparencies; (b) the transcriptions of the audio recording of the interaction during the class sessions; and (c) the transcriptions of the audio recording of interviews with two groups of future teachers (conic sections and arithmetic and geometric progressions) at the end of the sessions on subject matter analysis and at the end of the course.

The identification and characterisation of the partial meanings of the groups of future teachers was the result of a cyclical exploratory process in which I codified and analysed the information available from the three sources mentioned. The process was based on the simultaneous analysis of the transparencies of the groups of future teachers and the transcriptions of the recordings of the interaction in class and the interviews with the two groups. It was exploratory because, on the basis of the reference meanings of the curriculum organisers of the subject matter analysis and using the development factors as a guide, I identified the information contained in the transparencies and the transcriptions that I considered significant to the development of didactic knowledge of the groups of future teachers. I codified this information and organised and reviewed the codification several times as the codification scheme and the analysis evolved. To achieve this, I developed an interconnected system of databases.

My interest centred on identifying issues in the information contained in the transparencies and the transcriptions that would enable me to characterise evi-

dence of the partial meanings in the groups of future teachers. At the time, I called these issues “characterisations”. Each characterisation could be linked to various transparencies and episodes, as all constituted evidence of the same partial meaning. The analysis proceeded by identifying the episodes and documents that were most representative of the development of didactic knowledge of the curriculum organisers of the subject matter analysis and establishing characterisations for each of them. The interactive, coordinated system of databases enabled me to identify, for each characterisation, the evidence (episodes and documents) that best supported it.

I will now present the results of this analysis. The scope of this summary does not permit me to present either the evidence (transparencies from the groups of future teachers or transcriptions of the classroom presentations or interviews) or the methodological details of the analysis.

### **9.2. The Complexity of the Notion of Conceptual Structure as Instrument**

The analysis enabled me to characterise the partial meanings of the notion of conceptual structure that the groups of future teachers showed in their transparencies and their class presentations.

#### *Instrumental Genesis for Conceptual Structure*

The use that the groups of future teachers made of the notion of conceptual structure and of conceptual maps as instruments to describe the topic evolved over time. Some groups began the description of their topic with a disordered list; later, this list took the form of a conceptual map organised around a variety of criteria. Most of these organisation criteria came from the curriculum organisers. As the presentations and discussion of them advanced, the number of organisation criteria was reduced, and the organisation of the conceptual maps focused on systems of representation. The organising role of systems of representation also went through various stages. At first, it shared the role of organising with other notions, assuming in many cases a complementary role. Making the step to a conceptual map organised entirely by the systems of representation occurred at different times in the course, depending on topic. Only when the systems of representation assumed a leading role in the organisation of the conceptual map did the future teachers become aware of the possibility of establishing relationships between their elements. The fact that reaching this awareness was not simultaneous in the different groups created situations of class interaction that promoted the negotiation of meaning. Finally, most of the groups established a certain number of connections in their conceptual structure, recognised that “everything is related” and emphasised the importance of these connections.

#### *Conceptual, Historical and Phenomenological Approaches to the Organisation of the Conceptual Structure*

In addition to systems of representation, the organisers of history and phenomenology played significant roles in the process by which the groups progressed in their description of the mathematical structure based on the notion of conceptual structure. Historical analysis provided information that, in many cases, became relevant for the construction of the conceptual map.

The notion of phenomenology can be used as organiser of the conceptual map. In the year we performed this study, no group developed this possibility in depth. This is certainly the consequence, among other reasons, of the emphasis given in the instruction to systems of representation as a main organising criterion. In this alternate approach, the purpose is to identify and relate elements of the conceptual structure based on their phenomenological meanings. The concepts and relationships between them are organised according to their uses (natural, social and mathematical). For example, in the case of the topic of fractions, it is possible to organise the conceptual structure based on four categories: part-whole, measure, quotient, operator and ratio.

Several groups of future teachers tended to organise the conceptual maps following a “conceptual” approach. This approach seemed to arise naturally from a formal view of the mathematical structure: a concept is completely described by its definition. To express this description in a conceptual map, it is enough to identify the elements of the definition and the concepts and procedures related to it. However, most of these productions lacked meaning: they were a set of partially connected labels, interpretation of which requires the reader to bring his own mathematical reasoning into play. The emphasis on this kind of conceptual description may be one of the reasons that some groups did not recognise the potential of systems of representations as a tool for describing the mathematical structure. For these groups, the task of analysing the topic based on systems of representation was an independent task. Systems of representation thus became something complementary to the conceptual structure. When the groups recognised the descriptive and structural role of systems of representation and these began to play a larger role in organising the conceptual map, the conceptual approach lost its formality and elements that were previously labels began to have meaning. Representing elements of the conceptual map in different systems of representation allowed connections to be established between them, and these connections gave them meaning.

### **9.3. The Complexity of the Meaning of the Notion of System of Representation**

The groups of future teachers presented two transparencies whose main focus was the analysis of their concept from the perspective of systems of representation. However, systems of representation continued to play a role in the future teachers’ subsequent analyses. In the study I presented in the previous section, I detected that the groups had some difficulties with this curriculum organiser, since the variable “variety in systems of representation” was the third variable in number of discrepancies. What are the characteristics of these difficulties, and how were they overcome? How can we characterise the process by which the groups of future teachers negotiated and constructed the meaning of the notion of system of representation?

Some groups of future teachers considered that the symbolic representation aspect of their topic<sup>169</sup> formed part of its conceptual dimension and was therefore not a system of representation. For them, the symbolic served to describe the con-

---

<sup>169</sup> In what follows, “the symbolic”.

cept from its definition. In including the symbolic under the conceptual, several groups of future teachers considered graphs as equivalent to the idea of representation. However, these representations played a secondary and complementary role, since they believed that graphs represented specific instances of the concept and thus did not enable generality. Further, some future teachers suggested that these representations could induce to errors. The lesser importance they gave to these systems of representation can be explained by the role that these systems had played in the future teachers' earlier education, by the fact that the future teachers believed that in the textbooks they were used as examples—and thus in practice—there was not time to treat these systems in depth. However, when a variety of systems of representations appeared in the transparencies, this variety emerged mainly around the graphic systems of representation. This partly explains the tendency of the future teachers to impose a hierarchy in the systems of representation, a hierarchy supported by historical, conceptual, phenomenological and practical arguments.

As the future teachers advanced in the process of revising a task and producing a new version of the analysis, new systems of representation appeared. At first, they took into account only the basic (symbolic and graphic) ones. Later, at the end of the period devoted to subject matter analysis, a great variety of systems of representation appeared. However, when it came to bringing this information into play in cognitive and instruction analysis, the groups of future teachers reverted to the basic systems of representation.

The systems of representation that the groups of future teachers proposed in their transparencies can be grouped into several categories. I have already mentioned the basic systems of representation (symbolic and graphic). Some groups proposed systems of representation that were not really systems of representation (e.g., phenomena). The numerical and geometric systems of representation appeared later in groups who had reason to use them. Finally, some groups proposed systems of representation specific to their topics (for example, that of matrices for systems of linear equations).

Throughout the course, our instruction sought to develop a formal conception of the notion of system of representation based on the meaning proposed by Kaput (1992). However, the meaning that the groups of future teachers showed in their transparencies was closer to the conception put forth by Castro and Castro (1997), who emphasise aspects of visualisation and classify systems of representation into symbolic and graphic (p. 102). In any case, the meaning of the notion of system of representation expressed in the transparencies was partial, confirming the results of the analysis that I presented on the notion of conceptual structure. These analyses showed the low number of internal connections within each system of representation and between systems of representation indicative of the fairly superficial way the groups of future teachers used this curriculum organiser. The process of instrumental genesis was therefore partial: the groups of future teachers developed strategies for using the curriculum organiser as an instrument for analysis of a concept, but they did not succeed in deepening their strategies to use the information that emerged from this analysis in other phases of didactic analysis.

#### **9.4. Phenomenological Heterogeneity**

The analysis of a mathematical concept in terms of its phenomenological meanings is a complex process. This complexity became clear in the transparencies and presentations of the groups of future teachers. Most of them had multiple difficulties constructing the meaning of this curriculum organiser and managed to use it in practice on only a few occasions and incompletely.

The transparencies of the groups of future teachers show great variety in their approaches to the notion of phenomenology. The evolution of the partial meanings in the groups of future teachers did not follow stable patterns. Their transparencies show different solutions to the tasks proposed. In a small proportion of their transparencies, some groups approached the reference meaning proposed in the instruction. For each aspect of this reference meaning, there are transparencies that show this aspect. But only a few productions suggested that the groups of future teachers did use a complete and coordinated view of this meaning. In terms of instrumental genesis, the groups of future teachers did not manage to develop strategies for using the curriculum organiser that could enable them to convert it into a useful instrument, either for analysis of the concept or for putting this analysis into practice in the design of teaching and learning activities.

The progression of transparencies from the groups on conic sections and the sphere showed that the groups of future teachers can advance in the construction of the meaning of the notion of phenomenology, although with difficulties and only partially. The work of the group on probability showed that it is possible to perform a detailed phenomenological analysis, as the instruction required. On the other hand, the transparencies of several groups showed that it is possible to propose mathematical models and to identify laws and substructures without being able to perform a detailed phenomenological analysis that establishes relationships between the structural characteristics of the phenomena and elements and relationships of the substructures.

Fewer than half of the groups managed to develop a detailed phenomenological analysis and, in these cases, the effort did not lead them to go back and organise the phenomena according to the corresponding substructures. In fact, only three groups organised their transparencies by substructures, and only one of these kept this approach in the final project. Most of the groups organised the final project according to a different criterion than that used in their previous transparencies. This may be due to one of the examples given during instruction, but it also shows the weak consolidation of the meanings constructed by the groups of future teachers.

To the difficulty inherent in the curriculum organiser and of putting it into practice, we must add the fact that we dedicated very little course time to this topic compared to that devoted to the notions of conceptual structure and systems of representation. This situation permitted only one brief presentation of the theoretical aspects and very little depth in the development of examples and discussion of the work by the groups of future teachers.

### **9.5. The Complexity of the Notions of Subject matter analysis and Instrumental Genesis**

The difficulties shown by the groups of future teachers in working with the curriculum organisers of the subject matter analysis are, at least in part, the result of the complexity involved in these notions. From a theoretical perspective, these notions are complex, as was shown earlier. But the theoretical meaning of the notions is only one aspect of their complexity. This complexity increases when we take into account their technical and practical meanings. To bring these meanings into play, future teachers must develop strategies that enable them to transform each curriculum organiser of the subject matter analysis into an instrument that is useful from a didactic perspective. On the one hand, the future teachers must construct the necessary strategies for analysing a concept in order to identify, organise and select their different meanings. On the other, they must construct the strategies that enable them to use the information that emerges from these analyses in other analyses of didactic analysis and in the design of a didactic unit.

The complexity of the notions of subject matter analysis can be seen in this study in the three issues just mentioned. The persistence of some groups of future teachers in not considering the symbolic to be a system of representation or in proposing the phenomenological as a system of representation shows their difficulties in tackling the theoretical meaning of these notions. In most cases, the groups of future teachers overcame these difficulties during the course. However, taking this step did not mean that they were able to bring the notion into play to identify the different meanings of the concept, as I have shown for the notion of phenomenology. In the cases where this analysis was performed in some depth, as in the transparencies of several groups for the notion of systems of representation, it did not mean that these groups had developed the strategies needed to use this information for didactic purposes.

The three issues I have just mentioned are related to the three processes that comprise instrumental genesis. At the end of the course, the groups of future teachers managed the process of instrumentalisation for the notions of conceptual structure and systems of representation and in part for the notion of phenomenology. Instrumentation was achieved to a good extent in the case of conceptual structure and systems of representation. Orchestrated integration took place in part for the notions of conceptual structure and systems of representation.

The results I have presented in this section allow me to clarify some aspects of the process of instrumental genesis for the specific case of the curriculum organisers of the subject matter analysis. This provides evidence that the transformation of a curriculum organiser into an instrument is a dynamic two-way process. The analysis of the mathematical structure and the construction of the meaning of each curriculum organiser interact dynamically. As the analysis advances, more complex meanings are constructed (of the curriculum organiser and of the concept) that, in turn, enable new and deeper analyses.

The characteristics of the groups' transparencies depend therefore on two factors: the meaning that the groups construct for each curriculum organiser and the depth with which they study and analyse (using this notion as an instrument) the mathematical structure that corresponds to their topic. The initial meaning of the curriculum organiser enables only a general description of the mathematical struc-

ture, and the effort to deepen the analysis of the mathematical structure contributes to the development of the notion's meaning. This duality can be seen, for example, in the process of moving from a variety of organisational criteria to only one: the meaning of the notion is established, and the description of the mathematical structure improves. We can thus see the interplay between the theoretical, technical and practical meanings of the curriculum organiser. The development of didactic knowledge of the groups of future teachers is based on this interplay among theory, technique and practice.

The foregoing reflections allow me to clarify and adapt V erillon's model of situated instrumented activity (2000, p. 7). In Figure 102, I have adapted the names of the elements of the model to the context of the course. The evidence presented in this study shows that the relationship  $G(O) \leftrightarrow C$  is cyclical. With one meaning of the curriculum organiser as instrument ( $G \rightarrow O$ ), the group can analyse (with the mediation of  $O$ ) the concept in some depth ( $O \rightarrow C$ ). On determining the results of this analysis ( $G \rightarrow C$ ), they recognise new meanings for the curriculum organiser as instrument ( $C \rightarrow O$ ) that transform the group's practice ( $O \rightarrow G$ ) and enable them to advance in their understanding of both the curriculum organiser ( $G \rightarrow O$ ) and the concept ( $G \rightarrow C$ ). This is a variation on the idea of epistemological mediation suggested by Rabardel (2003, p. 668) by which the instrument contributes to the understanding of the object.

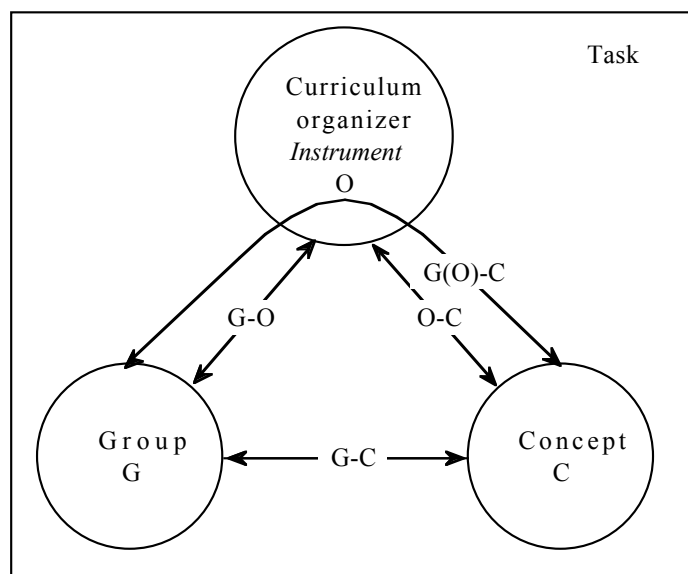

Figure 102. V erillon's model of situated instrumented activity adapted to the course

### 9.6. Complexity of School Mathematics

When each group chose its topic, its members assumed that the topic was simple, mathematically speaking. This view changed as they developed their topic in greater depth. The groups of future teachers expanded their view of what a

mathematical structure was. Their experience as mathematics students and as teachers in private classes had surely reinforced an essentially formal view of mathematical concepts. It is possible that this way of seeing things was at the heart of the difficulties they experienced in understanding the complexity behind each topic. However, as instrumental genesis took place and the groups of future teachers progressed in the identification and organisation of the different meanings of the mathematical concept, they became aware of its complexity. The results of this study show that most of the groups of future teachers were able to tackle this complexity from conceptual and representational perspectives. However, to some extent, this complexity overwhelmed them when they had to use the results of their analyses for didactic purposes. When it was expected that they would use the information gathered to design evaluation tasks or activities, the groups of future teachers reverted to the traditional elements: a conceptual view that uses basic systems of representation and does not take advantage of the phenomenological analysis.

### **9.7. Development of Didactic Knowledge and Communities of Practice**

The results of this study illuminate the process by which the groups of future teachers constructed the meaning of the curriculum organisers of the subject matter analysis socially from the work plan established in class. The analysis suggests that the development of didactic knowledge is a dynamic and cyclical process that can be promoted by teaching.

The analysis shows that the groups of future teachers negotiated and constructed the meaning of the curriculum organisers as they tried to use them in practice on a specific topic. Advances were achieved when, having proposed a solution to the problem, the groups of future teachers compared their solution to the solutions of the other groups and contrasted their position with the opinions, comments and critiques of their classmates and trainers. In this process, the future teachers were able to recognise the deficiencies in the initial solution, take into account the critiques received on it, research the scholarly literature and discuss new proposals to arrive at a new solution that arose from agreement among the members of the group.

The foregoing reflections stress the role of the community of practice in the classroom in the learning of the groups of future teachers. This is unquestionably an important issue in the development of their didactic knowledge, although one that I will not develop in greater depth in this study. I will focus my attention on the composition and consolidation of the communities of practice of the groups in their work outside the classroom.

## **10. PUTTING DIDACTIC KNOWLEDGE INTO PRACTICE**

In the third study, which I present in this section, I analysed the final projects presented by the groups of future teachers. I did this from the perspective of how they bring didactic knowledge of subject matter analysis into play in these documents.



### **10.1. Use of the Information from the Curriculum Organisers**

The last activity in the course consisted of the production and presentation of a final project. In this document, the trainers expected that the future teachers would present the information that they had obtained from the curriculum organisers in a systematic and organised way and use this information to propose the design of a didactic unit on the topic on which they had been working throughout the course.

These expectations arose from the conceptualisation of didactic analysis as a procedure for curriculum design. According to this conceptualisation, the systematic and reasoned use of information allows the teacher to justify the design he proposes. This design should not arise only from intuition or experience: the teacher can justify the design of the meaning of this design as consistent with the information he has produced in the didactic analysis. The teacher thus has a basis for evaluating the possibilities of the design's success when it is put into practice.

In this study, my interest focuses on exploring, in each of these documents, (a) what information, from the proposal in the subject matter analysis, was used in the analyses of the didactic analysis and in the design of the didactic unit and (b) whether information related to the subject matter analysis was used in the other analyses or in the design of the didactic unit that was not registered explicitly in the subject matter analysis section of the document.

### **10.2. Subject matter analysis in Practice**

As trainers, we expected to see a relation between the information that each group gathered and organised in the subject matter, cognitive and instruction analyses and the design the group proposed. We also expected some connection between the different analyses, such that the information that each group produced for an analysis (for example, cognitive) was supported by the information gathered in the other analyses (for example, subject matter analysis).

The analysis of the final projects shows that these goals were not fully achieved. The final projects of several groups of future teachers show a weak relationship between the information gathered for the curriculum organisers from the subject matter analysis and its use in other analyses and in the design of the didactic unit. The analysis also shows that the groups of future teachers used the information that emerged from subject matter analysis only in some aspects of the other analyses and of the design of the didactic unit and thus did not necessarily succeed in developing a global and integrated vision of subject matter analysis in particular and didactic analysis in general as a tool for designing didactic units.

From the perspective of the curriculum organisers of the subject matter analysis, we see that phenomenology was used specifically in the proposals from the class sessions but little in the other sections of the document. The information on conceptual structure and systems of representation was used especially in the sections on cognitive analysis, materials and resources, and objectives and content. This suggests that the information was useful, but only in some aspects of the process. In terms of instrumental genesis, these results suggest that several groups of future teachers were not able to construct and develop techniques (reasoning and procedures) that enabled them to see the importance of the information produced in subject matter analysis and to use it in the other analyses of didactic analysis and in the design of the didactic unit.

This study presents evidence to confirm a conjecture that most of us share as trainers of mathematics teachers interested in the development of the competence of planning: the systematic and grounded design of a didactic unit is a complex process. The results I have presented in this study (a) show that the curricular designs proposed by the groups of future teachers cannot be judged as “high quality”, (b) emphasise some of the difficulties that they faced and (c) suggest the need for instruction to emphasise more strongly the importance of basing and justifying this design on the information gathered for the curriculum organisers.

## 11. A COMMUNITY OF PRACTICE

In the three previous sections, I have tackled from different perspectives the last of the four questions that I formulated at the start of this document:

*What characterises the learning processes of the groups of future teachers who participated in the course?*

Until now, I have shown that the learning of the groups of future teachers can be characterised in terms of some states of development of didactic knowledge, and I have described these states. The results of these studies emerged from the codification and analysis of the transparencies used by the groups of future teachers. The transparencies used by one group to make the presentation on a topic are, in general, the fruit of several hours of work and discussion by its members. The groups present their work as a finished project in which one cannot see the process that gave rise to it. But what is this process? How does learning take place in a group of future teachers when, working outside the classroom, they prepare the presentation and then deliver it to their classmates? The analysis of the transparencies of a group of future teachers illustrates, only partially, their learning, as there are many aspects of a group’s learning that cannot be seen in its productions. When we see the performance of the future teachers, we cannot know where their actions came from or what happened in the group’s discussions and negotiations that was not expressed in their productions. At the end of the previous section, I characterised this problem as one of the questions that remained unresolved in this research project: the exploration of the process by which each group of future teachers negotiates meaning and advances in its learning process when it works outside the classroom preparing its presentations.

In this section, I tackle this question by presenting the results of my analysis of the audio recordings of the work meetings outside the classroom held by one of the groups of future teachers who participated in the course. This was the group that worked on the quadratic function. I had two goals in this study: (a) to describe the evolution of didactic knowledge of this group of future teachers and (b) to use this information to explain some of the results obtained in the other analyses.

I grounded the study conceptually in Wenger’s social theory of learning (1998). I chose, interpreted and adapted the most relevant aspects of this theory to the characteristics and purposes of the study. From this adaptation of the theory, I designed some instruments that allowed me to codify, analyse and interpret the transcriptions of the audio recordings of the group meetings. I will now describe the processes of codification and analysis that I designed to tackle the problem.

The body of this section is concerned with characterising and grounding empirically the 32 questions that constitute the results. At the end of the section, I will use these results to characterise the group on quadratic function as a community of practice and to reflect on some of the implications of the study.

### **11.1. From a Theory to some Instruments for Codification, Analysis and Interpretation**

Recall that learning in practice implies the mutual commitment to a joint enterprise with a shared repertoire. That is, learning emerges to the extent that (a) different forms of mutual commitment evolve; (b) the enterprise is understood and refined; and (c) the shared repertoire, style and discourse are developed.

The evolution of different kinds of mutual commitments is characterised by the influence of environment (what helps and what hinders), how identities are defined, how the relationships develop, and how meaning is generated, negotiated and materialised. The process of understanding and fine-tuning the enterprise is characterised by the role of external conditions, the characteristics of the discourse (what is discussed, expressed and valued) and the definition of the enterprise and responsibilities. And the development of the shared repertoire is characterised by the styles of expression, work routines and resources for negotiating meaning. I will develop the characterisation of each of these processes in greater depth later when I analyse the information that corresponds to each of these dimensions.

Wenger's social theory of learning does not have an operational character. My problem was thus conceptual and methodological: how to codify and analyse the information to characterise the phenomenon in terms of the theory? That is, how to establish categories and values of codification and analysis that, based on theory, would enable me to select and structure the relevant information and identify the most significant questions about the learning of the group of future teachers? In the first phase of the process, I identified and structured some of categories of analysis. These categories were the link between the central ideas of the theory and the codes that compose the instrument to examine, select and articulate the information. The categories for analysis emerged from a detailed and purposeful reading of theory. After first reviewing the transcription of the audio recording of the meetings of the group of future teachers, I interpreted and selected ideas and aspects of the theory in terms of this information. In this way, I gradually produced different versions of the list of categories until I felt that this list was coherent and meaningful with respect to the information.

I organised these categories according to the three dimensions that characterise learning in a community of practice: mutual commitment, joint enterprise and shared repertoire. Taking into account the meaning of each of these categories in the theory, I identified a series of questions that characterised the categories and were adapted to the phenomenon that I wished to study and the information available. For example, for the category of meaning of the dimension mutual commitment, I formulated the following questions: (a) What meanings were discovered, and how? (b) What difficulties of meaning appeared? (c) What reification events occurred? (d) What proposals for meaning were made, and how were they made? and (e) What proposals for meanings were adopted, and how were they adopted?

My information source was the recordings of part of the sessions of group work. The recorded sessions were distributed over the time that the group worked on didactic analysis and included the sessions for preparing the draft document, the document, and the final presentation. These audio recordings were transcribed. From the methodological perspective, my problem was to design and put into practice some instruments for codification and analysis of these transcriptions that would allow me to tackle the research questions. These instruments had to be based on the conceptual analysis I have just presented.

I then developed a preliminary system of codes, starting from the questions I listed above. This system evolved as I codified the transcriptions and perceived the need to include new codes. The final list contained 94 codes. For example, I established codes to identify episodes in which reference was made to the comments on the transparencies, responsibilities were defined and composed, and work routines established in the group.

The process of codifying the transcriptions consisted of identifying, registering and characterising the episodes. An episode is a part of the transcription, of varying length, which contains statements by one of the participants or exchange of statements among several group members. Its coherence lies in the fact that it revolves around an idea or message. From the codification, I produced a database in which each entry corresponds to an episode and a code assigned to this episode. Each entry includes notes with my interpretation of the interactions and identification of its more relevant aspects. The following is an example of an episode that I codified with codes corresponding to personal relationships, leader and complementary participation. In this episode, one of the participants, whose performance represents complementary participation, refers to the authoritarian attitude of the leader. The comment I assigned to this episode was the following: “Again, there is tension: they criticise the leader explicitly. He knows everything because he teaches” [100,73773,74154]<sup>170</sup>:

*P1: It is that he is the specialist now. Since he teaches, he thinks everything he says is great.*

At the end of the codification process, there were 7412 entries in the database. These entries corresponded to 2606 episodes, since one episode could be entered with more than one code and each pair of an episode and a code corresponds to an entry in the database.

It was clear that we had to summarise the information that emerged from codifying the information. In this synthesising process, I took into account theory (by means of the categories and questions) and the additional information that I registered during the codification (comments and notes). I designed several computer programs that enabled me to produce a summary of the content of the transcription of each recorded tape.

---

<sup>170</sup> In what follows, I identify an episode in the transcriptions with a triad [a,b,c], where a is the number that identifies the tape on which this part of the session is recorded and b and c identify (in number of characters) the beginning and end of the episode in the text of the codified transcription. Thus, the episode [066,27077,27458] is found between characters 27077 and 27458 of the codified transcription of Tape 66.

The analysis of the summaries of the codification of each tape allowed me to identify a series of issues that seemed relevant to the study. For example, from each analysis it became clear that there was a leader in the group and that his action determined various aspects of the learning process that took place. Therefore, characterisation of the leader and of his relation to the other members of the group was one of the issues worthwhile registering and analysing. This list of issues specified and summarised in a series of phrases (role of the leader, role of the comments on the transparencies, importance of the connections between systems of representation, etc.) the 950.5 minutes of recordings that I took as initial information for the study. I will identify and characterise these issues in the following sections.

The list was the final result of a process of *synthesis*. I gathered and organised the information corresponding to this list of issues in a new database, which became the starting point for a process of *analysis*. In this analysis of the codification, I imposed, for each of the issues identified in the synthesising process, two purposes: (a) to describe each issue, identifying its main characteristics and (b) to identify the most representative episodes of these characteristics in order to provide evidence for the characterisation of the issue.

Once I performed this procedure for each question of a specific aspect (e.g., “systems of representation” in the category shared repertoire), I produced a summary of the characterisation of the questions belonging to this aspect, together with the main results obtained. In each of the sections that follow, I organise the results that correspond to each of the three dimensions of the analysis.

### **11.2. Mutual Commitment**

I organised the analysis of the transcriptions related to mutual commitment, according to four dimensions: environment, identities, relationships and meaning. The analysis focuses mainly on the characterisation of the group’s processes for negotiating meaning and the factors that influenced this process.

#### *Processes of Negotiation of Meaning, Environment, Identities and Relationships*

Teaching experience, the assigning of practical exercises and textbooks are the three elements of the environment that most influenced the processes of negotiating meaning within the group. The intuitive knowledge that the participants had developed in their experiences as teachers enabled them to make multiple proposals for the cognitive analysis. Experience in the practicum played another role: it contributed information that enabled them to ground and validate arguments in group discussion. Textbooks contributed information for the conceptual structure and were a source of information that enabled the future teachers to validate statements and resolve questions. Textbooks also played a central role in the design of the didactic unit. The activities that the group proposed for the didactic unit emerged from the selection and transformation of exercises that they found in the textbooks.

The transcriptions showed the existence of a leader. He was the person who planned, directed and verified the group’s work. He also contributed most of the ideas. Parallel to the leader, some members assumed a complementary role: they

waited for the leader to indicate what they had to do, then presented him with reports on their work and waited for his approval.

Although the group generally maintained a relaxed work atmosphere, there were moments of tension in the sessions. These moments had to do, on the one hand, with the evaluation session in which the leader was absent and in which multiple conflicts of meaning were generated between two members of the group. On the other hand, there were moments of great tension between the leader and one of the participants, differences that reached the personal level but were later resolved.

In the sessions, one could see the constant effort to search for meaning. Confusion was an element of this search process and was expressed in situations where opinions concerning a topic changed or where tentative positions were assumed. Along with the confusion, situations of conflict of meaning appeared, where two or more members assumed incompatible positions with respect to a question. The group used different mechanisms to resolve the confusions and conflicts of meaning. In most cases, these resolution processes gave rise to new proposals of meaning that ended up being adopted by the group. Some of the proposals were the product of processes of discovering meaning, in which a new idea appeared that clearly contributed to the performance of the task at hand. Finally, many of these meanings gradually reified in the group.

Next, I present a summary of an example of one of the previous results: the episodes of confusion of meaning.

### *Confusion of Meaning*

I call episodes of confusion of meaning those in which, with respect to a particular question, one or more members of the group: (a) are not sure of its meaning, (b) change opinion about its meaning during the sessions, or (c) assume invalid positions with respect to this meaning.

In this section, I focus my attention on a question that is located mainly in the first two categories. It is a matter of the confusion between the notions of equation and function. The confusion appeared in the historical review that the future teachers had performed of the topic. At the beginning of the work, the group had already foreseen that there would be confusion about the meaning of these two notions. They waited to use the results of the historical investigation to relate them [043,1012,1554]. When they advanced in their investigation, the group produced a preliminary definition of the problem: it was a problem of how to move from the equation to the function [043,5910,6095]. One of the members of the group believed that he understood the difference between equation and function. However, this clarity disappeared when the members tried to establish the differences between the two notions. He moved from arguing that the function was the generalisation of the equation to ending up with an emphatic statement: any second-degree equation was a function [043,8000,10438]:

*P3: No, but I am speaking about us. Why this mess? Why do we think in one way. Equation and function. That is, function, when do we use the term function? When you have to give...,*

*P2: A relation between some variables, some magnitudes...*

*P3: A relation between one variable and another; between one magnitude and another. But the equation was there from the beginning. And a second-degree equation is just changing one thing with respect to the other; with the second-degree equation. This is a second-degree function. Therefore, we are going to talk about second-degree functions, and then we say...*

...

*PX: I think the generalisation of a second-degree function is already a function.*

*P3: It's already a function; it could be.*

*PX: No, maybe not; that's what it is.*

*P3: Well, it could be, couldn't it?*

*PX: And, it's that any second-degree equation is a function.*

However, the group thought that the problem was not serious, for they considered that historically the two notions had been the same [043,11147,11514]. At one moment in the discussion, the group seemed to agree on the partial meanings of the terms [043,11988,12518]:

*P4: ( ). Second-degree function, and what I think of is a parabola. But if I am seeing a second-degree equation, what I think of is the root.*

*PX: Find its zeros, right?*

*PX: Right.*

*PX: Up to there, we agree.*

*PX: Yes, we do.*

Here, the members of the group believed they were clear about the difference between the notions. The problem consisted of not being able to express this difference. However, conflicts appeared with the statements that had been made before, since “an equation is not the same as a function” [043,14683,17431]. This confusion and the difficulties it created generated enthusiasm for the historical research, because they thought this could resolve some of the issues in the question [043,48717,49586]. At this point, they stop making references to the relationship between equation and function from the historical perspective. However, this duality reappeared in the discussions of errors and difficulties. The confusion took specific form at the time as a students' difficulty [066,20856,21436]. However, in trying to express the difficulty, the group became confused again [100,6435,7622]:

*P1: Ladies and gentleman. I have made five big problems, all by myself. First problem: identification of a second-degree equation. Possible mistakes.*

*P2: Of an equation?*

*P1: Of an equation ( ) equation; of the expression of a second-degree equation. Well, or of a function, if you wish. I take the lead coefficient 1; not to recognise the second-degree equation in the multiplicative form: to identify the roots.*

To conclude, in the session on preparing the draft of the didactic unit, the confusion appeared again, this time in the form of a joke toward the essentially symbolic attitude of one of the members of the group [101,92686,93099]:

*P2: ( ) And what are you going to say about second-degree functions? That they are the ones like equations but without the zero; and instead of the zero, you put  $f(x)$ .*

*P4: ( ) (Laughter).*

*P1: ( ) Come on.*

### 11.3. Joint Enterprise

The process of understanding and fine-tuning the joint enterprise (fine-tuning the commitment, composing the responsibilities, defining the enterprise and its interpretations) is the second element that characterises learning in a community of practice. In this section, I describe and characterise the main processes by which the group constituted and developed the joint enterprise. According to the conceptual framework of the study, I expect that the joint enterprise of a practice is negotiated collectively and continually and creates relationships of mutual responsibility among the participants. The enterprise is the response and adaptation of the participants, with their limitations and resources, to the external conditions; but it is never completely determined by external command. In the case of the community of practice in this study, the constitution and development of the joint enterprise was based on two interrelated processes: (a) the definition of the enterprise and its interpretations, taking into account the external conditions that affected it and (b) the composing of the responsibilities and the development of the commitment, with special attention to the constant attitude toward the efficiency of the work performed.

The definition of the enterprise was conditioned by the conditions intrinsic to the tasks that the group had to complete (interpretation of the task and difficulty and extent of the topic to be treated) and by conditions external to the community of practice (comments on transparencies and comments by the trainers). I will now present a summarised example of one of the previous results: the role of the comments on the transparencies.

#### *Comments on the Transparencies*

In the work done by the group on quadratic function, I found evidence that suggests that the comments on the transparencies played an important role in the group's construction of meaning. This role was expressed in the fact that the comments served as a reference for validating the proposals that the group had made. On several occasions, the group accepted these comments blindly, assumed them as an authority to resolve confusions and conflicts and recognised their role explicitly. This was the case in the construction of the meaning of the notion of phenomenology. The group read the comments several times, until one of the



members understood the idea of analysing by means of substructures of the mathematical structure of the quadratic function. This participant used the comments as a source of authority to convince the others of the ideas necessary to perform the phenomenological analysis and developed these ideas gradually to organise the work in this area. The role of the comments on the transparencies was delayed. Only on a few occasions when preparing a presentation did the group take into account the comments made on the previous presentation. This was normal, given that the topics of two successive presentations, although related, were different. However, the comments on the transparencies came up again when the group was preparing the work on the didactic unit. The group returned to this information and used it to change, improve and deepen the proposals they had made during the course.

In the first meeting with the trainers to prepare the didactic unit, the group recognised explicitly the role that the comments on the transparencies had played [096,15912,16553]:

*P5: Let's leave the historical route for last (.). Let's see. In phenomenology, and following the recommendation we have, we have..., the first structuring we did considered mathematical phenomena and non-mathematical phenomena.*

The group recognised the importance and usefulness of organising the phenomena based on substructures of the structure of the second-degree function, thanks to the interpretation and discussion that they had about the comments on the transparencies. In the next episode, P2 recognises explicitly that the comments have “given him a clue” on how to complete the task [098,32775,34767]:

*P1: We're coming back to the same thing. It says: "the classification of the non-mathematical phenomena in physics and outside physics is a little artificial, from the perspective of the mathematical structure in question. All these phenomena are, simply, non-mathematical phenomena", which is what I told you. "In this large family of non-mathematical phenomena, you make a classification by areas of knowledge: physics, chemistry, biology, economics and (.). But this kind of classification does not let you establish a relationship between the structural characteristics of the phenomena..."*

...

*P1: But now it's a matter of doing it.*

*P2: I know, but (.) it's given me a clue.*

The role of the comments on the transparencies as authority that enabled the resolution of confusion and conflicts in meaning can be seen in the next episode. The group did not understand the comments on the transparencies easily. On many occasions, they had to make an effort to interpret them, which contributed to the social construction of meaning. This can be seen in the first session on preparing the draft of the didactic unit, when they tried to solve some problems related to the phenomenological analysis [098,25257,27564]:

*P2: Let's see (.).*

*P3: Read it again; read it again.*

*P2: That's it. But if I read it to you now. "In class the comment was already made that the term modelling of phenomena is too general and does not necessarily contribute to the phenomenological analysis. The problem of phenomenological analysis is precisely to identify the family of phenomena and classify it according to the mathematical structures that organise it. For example, the mathematical substructure that organises the phenomena of areas are second-degree functions of the form  $f(x)=ax^2$ ". And from here there are lots of... Let's say, from this, from this kind of second-degree function, well, come lots of phenomena. They can be mathematical or non-mathematical phenomena. It doesn't matter. They all get put together, since they come from the function  $f(x)=ax^2$ . Then it says: "but this substructure doesn't allow you to organise the problems related to the space and time of the phenomena of a movement..." Let's say, a uniformly accelerated movement; because the second-degree functions that model this kind of phenomena are these. And from these functions, we get: this, this, this, and this. And they can be mathematical or non-mathematical. But from this kind of function we get all these phenomena.*

*P3: ()*.

*P2: () that we have to find the family... Let's say, the mathematical substructures of the function and, from there, get the phenomena, whatever kind they are. Let's say, that we have to do the organisation starting from the conceptual structure.*

*P3: ()*.

*P2: And that's what I'm trying (), but it's not easy.*

#### **11.4. Shared Repertoire**

I focus the analysis of the transcriptions, from the perspective of the development of the shared repertoire, on two issues: the development and establishment of work routines and the evolution in the construction of meaning of the three notions that make up subject matter analysis: conceptual structure, systems of representation and phenomenology. For each of these notions, I explore two aspects of the process of construction of meaning: the main difficulties of meaning and their processes of resolution and reification, and the putting into practice of these meanings in other analyses of didactic analysis. I now present a brief summary of the results obtained.

*Work routines.* The group, with the guidance of the leader, developed and established work routines for the activities in the sessions, the individual activity outside the sessions and the activities related to specific tasks during the sessions. These routines were of two kinds: individual work that was subsequently communicated to the others and exploratory work with brainstorming.

*Conceptual structure.* Instruction insisted systematically on the topic of the connections within the conceptual structure. In the group's first productions, there were some relationships between systems of representation. However, the group became aware of the importance of this aspect of the conceptual structure when they were preparing the draft of the didactic unit. At this time, the group succeeded in differentiating the conceptual structure clearly from the systems of representation.

From the perspective of putting it into practice, the conceptual structure played a role in both cognitive analysis and instruction analysis. In the former, it served as a reference for verifying, locating and organising errors and difficulties. In the latter, it served as a guide for organising the sequence of ideas tackled in the didactic unit.

*Systems of representation.* Systems of representation were the predominant curriculum organiser in the group's productions. The work focused, with the goal of specifying the topic, on symbolic and graphic systems of representation. The transcriptions showed an evolution in the construction of the meaning of the connections between systems of representation. This topic began to be important in the cognitive analysis, when the group recognised that it could be at the root of one of the students' difficulties. Although there is no evidence that the group had had difficulties with the notion of system of representation, two difficulties do appear that are related to the notion. On the one hand, from the first session, the group did not succeed in differentiating clearly the notions of quadratic equation and function (seen from an exclusively symbolic perspective). On the other, when they went into detail on the connections between the symbolic and graphic systems of representation, the group did not manage to use the technical aspects of the graphic meaning of the parameters of the symbolic forms of the quadratic function fluidly. The first difficulty was resolved gradually throughout the sessions. For the second, the group found only a partial solution.

Systems of representation were put into practice in the phenomenological analysis, the cognitive analysis, and curricular design. In the phenomenological analysis, they gave rise to categories with which the phenomena were organised. In the cognitive analysis, the notion of connection enabled the group to identify one of the students' difficulties. And, in the design of the didactic unit, systems of representation were a central topic of its goals and contents. Further, the group used systems of representation to develop a procedure that allowed them to select and organise the problems in the textbook. The group used this selection and organisation to design the activities that composed the didactic unit.

*Phenomenological analysis.* At first, the group faced difficulties related to the meaning of the notions of phenomenon and modelling. These difficulties were at the source of a preliminary organisation of the phenomena into four categories:

mathematical phenomena, non-mathematical phenomena, areas of geometric figures and modelling. This organisation only changed due to the review of the comments on the transparencies during the session to prepare the draft of the didactic unit. At this time, the group discovered, negotiated and reified the procedure of analysis by substructures.

However, in the curriculum design, the relationship between the phenomenological analysis and the design of activities was weak and intuitive. There are only references to “verbal exercises” and everyday situations as a means to motivate the students and to introduce some topics and ideas.

Next, I present a summarised example of one of the previous results: the discussion of the graphic meaning of the parameters of the symbolic forms of the quadratic function.

#### *Graphic Significance of the Parameters*

Discussion on the graphic meaning of the parameters of the symbolic forms appeared in the session on preparing the didactic unit. Up to this time, the meaning of the connections between symbolic and graphic systems of representation had been general. The specificity of these connections (with respect to the parameters) arose from the need to design in detail the activities that would be proposed to the students in the sessions to make up the didactic unit. Tackling this problem generated confusion and made explicit some of the difficulties that they had in the mathematical handling of their topic. These difficulties became evident in the use of the graphic significance of the parameters of symbolic forms.

The doubts and confusions on this topic can be seen in the following episode, in which questions arose about the role of the parameters in locating the intersections of the function with the  $x$  axis [102,121228,122206]:

*P4: So, the points of intersection with the  $x$  axis influence the other coefficients of the function. Don't they?*

*P2: Yes, but.*

*P3: Wait.*

*P4: Let's see.*

*P3: What are you trying to say?*

*P4: Bartolo is saying... Bartolo is saying that, when you have seen the general characteristics..., such as, for example, you have just seen the intervals of increase and decrease, these depend on the lead coefficient, as it says here. That's what you're saying.*

*P4: Then, I say the same thing that is being said about the lead coefficient, when you see the points of interaction, you will have to say how they influence all the other coefficients. Because here is the influence. Because in the other one, it is true that they influence all of them. In the points of intersection, all three have influence. Don't they?*

When they reflected on the role of the parameter  $a$  in the expression  $f(x) = ax^2 + bx + c$ , they came to think that all of the characteristics of the graph of the function depended on this parameter [100,89677,90153]. But, as is natural,

they encountered the greatest difficulties with the meaning of parameter  $b$ . These difficulties appeared at the beginning of the session, when one of the members asked explicitly about the graphic meaning of this parameter [105,4318,4424]. In discussing this topic, they came to think that this parameter alone did not have any influence [105,14822,15530] and reverted to the algebraic reflection to focus the graphic meaning of the parameter in its influence on the location of the function's intersection with the  $x$  axis [105,95236,96157]. Finally, they established that this parameter influenced the horizontal translation of the vertex, but they did not realise that this influence was linear, while the effect on the vertical position of the vertex was quadratic [105,98785,99239]:

*P2: When the sign of the coefficient of  $x$  is negative, the thing is translated..., always to the right, I think.*

*P3: ( ) would be  $x$  -... Let's see; if it's negative, it is to the right. The positive... (Several people talk at the same time).*

*P2: The positive to the left. Yay! That's it. There you have it. ( ) the  $b$ . (Several people talk at the same time).*

*P4: If it's negative, it's to the right.*

In the end, some of the members did not understand the details of the discussion, and the confusion was not clarified in the group, although the didactic unit contained activities that tackled the problem [103,111313,111426]:

*P2:  $x^2-1$ .*

*P3: You understand, don't you, ?*

*P1: No, I don't. ( ).*

### **11.5. Development of Didactic Knowledge: Technical and Practical Meanings**

The group did not seem to realise that the notions it was putting into practice when it performed these tasks had a theoretical meaning. The group's concern focused on interpreting the technical meaning of the notions: the use of notions to analyse their topic and perform the task at hand. The process of negotiation of meaning that took place when the group performed the tasks contributed to the construction of both the technical and the practical meanings of the notions. Didactic knowledge was constructed in a constant (and in most cases unconscious) interplay between the technical and practical meaning of the notions involved.

The analysis of the results indicates that some aspects of the community of practice studied seemed to influence their learning practice systematically. These were the following: (a) the teaching experience of the participants, (b) experience in the practicum, (c) the comments on the transparencies, (d) the existence and role of the leader and (e) the commitment of the participants.

### **11.6. Community of Practice: a Tool for Seeing, Thinking and Acting**

In using Wenger's social theory of learning (1998) to ground the study conceptually and methodologically, I made a decision that was not free of risks, since it was not clear "to what extent one can apply this approach to learning in schools and universities and what implications it has for research" (Krainer, 2003, p. 96).

In this section, I will address these questions. I will show how, for the specific case of the study, the idea of community of practice became a tool for seeing, thinking and acting<sup>171</sup>.

*A Tool for “seeing”*

Using this study, I have been able to characterise the development of didactic knowledge of a group of future teachers from results that it is not possible to obtain in the other studies of this project. These results show that, behind the in-class presentations of the groups of future teachers and their projects, there is a complexity which is inherent to the development of a community of practice. By analysing this complexity systematically and in detail, I identified and characterised many aspects of social learning of a group of future teachers. I consider that these characterisations, with the level of detail in which I have presented them, are interesting and important in themselves. They illuminate dimensions of the initial training of high school mathematics teachers that often remain opaque in the research literature. They also enable us to explain some of the results of the other studies that form part of this project. For example, they enable us to understand the processes of negotiation of meaning that materialised in the transparencies and the group’s final project. They also reveal the different positions of the participants, their questions and confusions, the conflicts they had to face and resolve and the plans and techniques they developed to complete the tasks they were assigned. Finally, the in-depth analysis of the transcription illuminates the progress of the group in its commitment to constructing jointly the meanings that they believed necessary to satisfy both the requirements of the course and their interest in becoming mathematics teachers. I can thus explain and support with evidence some of the most important issues of the development of didactic knowledge of the groups of future teachers that I established in previous sections. I will analyse in detail the relationship between all of the studies in the next section.

I undertook this study from the perspective of a social theory of learning in which the idea of the community of practice is central. This theory emphasises aspects of learning that theories of learning focused on the individual ignore. The study shows that these issues are important in characterising the development of the didactic knowledge of future teachers. It determines not only *what* the group learns but also *how* it learns and *on what* this learning depends. It is, therefore, a broad view of the idea of learning in which context plays a central role and that emphasises the interdependent character of learning. The group learns because its members are mutually committed to a common purpose. To achieve this, they negotiate meanings that reify in a shared repertoire with which they complete the assigned tasks.

From the conceptual perspective, I gave specific meaning to the ideas that articulate learning in communities of practice in the context of the initial training of high school mathematics teachers and was able to design instruments for codification and analysis of this complexity. This kind of procedure was time-consuming, but it enabled me to tackle systematically a large body of data and obtain results whose validity is based on the process itself.

---

<sup>171</sup> “A theoretical discourse is not an abstraction. It is a set of conceptual tools that allows us to see, think and act in innovative ways” (Wenger, 2004, p. 2).

*A Tool for “Thinking”*

The results of the study show that the group on quadratic function constituted and consolidated a community of practice: in a continual process of seeking and negotiating meanings, the group established a mutual commitment in the definition of a common enterprise for which it produced a shared repertoire. The analysis of the transcriptions shows not only that the participants learned and progressed as individuals, but also that *interdependent learning* occurred: the group, as an entity, progressed in its capacity to tackle the tasks at hand, and each participant was concerned about the learning of the others. Since this was a case study, we cannot conclude that the other groups of future teachers in the course established and consolidated communities of practice. For example, a leader did not necessarily emerge in all of the groups. Further, analysis of the interaction in class and of the final documents suggests that some groups were organised as teams: they divided the tasks into sub-tasks, for which each member took responsibility. They then constructed the presentation as the sum of these parts. When a group is organised as a team, there is learning (Anderson y Specjk, 1998). However, the negotiation of meaning and interdependent learning are not inherent characteristics of a team’s learning processes (Krainer, 2003, p. 95). What was important in the case of the group on quadratic function studied here was the mutual commitment of the members in seeking and defining a joint enterprise that involved concern for the learning of all members of the group.

Group work is *one* of the contexts in which the learning of future teachers takes place in the course. For example, they also learn, individually and collectively, during class, when they do individual projects, in other courses, and when they give private classes. However, given that the evaluation plan of the course gave great importance to the presentations and the documents produced by the groups and that these presentations and documents were the result of group work, it is clear that we especially value the learning processes that take place when groups work outside the classroom. Because teaching takes place essentially in the classroom, we tend to think that most of the learning is done in this context. This study shows that this is not necessarily the case.

Although I have used the idea of community of practice as a research tool, its results show the possible benefits of tackling the design and development of the course from this perspective. Is this possible? What implications would it have?

*A Tool for “Acting”*

Teachers’ learning does not end at the university. Teachers continue to learn in their teaching practice in the educational institution. If we as trainers value the learning that takes place when a group works as a community of practice, how can we promote and cultivate this kind of scenario? To answer this question, the teachers’ trainers should be concerned not only with what we expect future teachers to learn and to be capable of doing, but also with how they learn and what kind of instruction is consistent with this learning. We should therefore review the design of the training plans from this perspective. This study suggests some elements of reflection along these lines. For example, I have shown the importance of the written comments of trainers and the definition of the tasks they assign to the future teachers. Next, I will suggest another element: advising of the groups.

The design of the tasks and comments on the groups' work can promote interdependent learning in a group *if the group has already been constituted as a community of practice*. In other words, in a group that works along the lines of a team, the members can interpret the comments and definition of the tasks as two additional conditioners of the work routines they have established, without these factors necessarily promoting the negotiation of meaning. But if we value the kind of learning that emerges from a community of practice, how do we foster and cultivate this kind of scenario? In our experience, we see that we must change our attitude as trainers. Until now, when we interact with the future teachers (in the classroom or in office hours), our concern has focused on *what* they have learned and in helping them to improve their work (transparencies, presentations and documents). However, we now realise that we must take into account the learning processes that give rise to the groups' productions and develop strategies that promote interdependent learning and negotiation of meaning. We must become "advisors" in the work of the groups. This involves being concerned with their learning processes. To do this, our attention should focus not exclusively on determining to what extent they have developed a shared repertoire and correcting their deficiencies. We must also pay attention to the factors that can affect both the development of mutual commitment between the members and the clarity and validity of their joint enterprise. The "model of the Aalborg project" (Hansen y Jensen, 2004) is an example of this kind of approach to professional training.

The foregoing proposal suggests a new characterisation of the teacher trainer. If the initial training of high school mathematics teachers is tackled from the perspective of communities of practice, we should question and reflect on our competences as trainers. Trainers must develop new competences, and this kind of approach imposes new requirements at the institutional level (Beck y Kosnik, 2001, p. 925). What factors that affect the "quality" of communities of practice can be promoted in the initial training of high school mathematics teachers? (Llinares y Krainer, 2006, pp. 444-445) What competences should we develop as trainers? What conditions are imposed at the institutional level? These are some of the questions we should tackle in the future.

## 12. ONE PHENOMENON, FOUR POINTS OF VIEW

This section presents the global and integrated analysis of the results of the empirical studies performed in this research project. My goal is to answer the fourth question I formulated in the first section:

*What characterises the learning processes of future teachers of high school mathematics who participate in an initial training programme?*

My intention is to integrate these results to characterise the development of didactic knowledge in the groups of future teachers with respect to the notions of subject matter analysis and to propose some conjectures to explain this process. The four studies describe the same phenomenon from different perspectives, and each emphasises specific aspects of this phenomenon.



I begin this section by listing the main characteristic of didactic knowledge that the groups of future teachers developed concerning the curriculum organisers of the subject matter analysis. This description reveals the complexity of these notions, a complexity that is also expressed in the interplay between the development of their technical and practical meaning. I will then identify some characteristics of the course and of its context that influenced and help to explain some aspects of the development of the didactic knowledge of the groups of future teachers. I end the section with a reflection on instrumental genesis in the context of initial training plans for high school mathematics teachers.

### **12.1. Didactic Knowledge and the Curriculum Organisers of the Subject Matter Analysis**

This section includes the results of the four studies and organises them from the perspective of learning in the groups of future teachers with respect to the three notions of the subject matter analysis. I stress the difficulties that the groups of future teachers encountered in using the notions to analyse their topic.

#### *Formal View of the Conceptual Structure*

The formal and symbolic view that most of the future teachers brought to the course led them to assume a conceptual approach to mathematical topics. In their first productions, they used what they had at hand to organise the conceptual structure: the curriculum organisers. The conceptual approach was simplistic and did not allow systems of representation to play the role they should have in the description and organisation of the conceptual structure. The symbolic became equivalent to the conceptual, and graphic systems of representation were seen as complementary to the formal description of the mathematical structure. To move beyond this impasse took time. The difficulties were overcome when the groups of future teachers became aware of the role played by systems of representation in the articulation of the conceptual map with which they described the mathematical structure and reduced the number of criteria of organisation: a lower number of criteria, greater organisation and complexity. Finally, the systems of representation assumed a leading role in the organisation of the conceptual maps, and the groups of future teachers became aware of the relations between the elements of these conceptual maps.

The groups of future teachers had to overcome difficulties to construct the meaning of the notion of conceptual structure and to use it efficiently in the description of the mathematical structure of the topic. As was the case with the other curriculum organisers of the subject matter analysis, the formal (theoretical) definition of the notion did not contribute significantly to the construction of its meanings. These meanings had multiple facets, and the groups of future teachers tended to construct it in practice in an evolving process in which the revision of a proposal and its contrast with the other groups and with the comments of colleagues and trainers gave rise to new, more complex and coherent proposals. The groups of future teachers advanced in the construction of meaning of this curriculum organiser as they used the other notions of the subject matter analysis (in particular, systems of representation) to analyse and describe their topic.

### *Hierarchy in Systems of Representation*

The four studies show that the groups of future teachers established a hierarchy in the use of the systems of representation to analyse their topic. This hierarchy was evident in the variety, organisation and putting into practice of this notion in their work throughout the course.

The groups of future teachers gave preference to the symbolic system of representation, equating it with the conceptual and not considering it to be a system of representation. As they advanced in their efforts to improve their productions, the meaning that the groups of future teachers constructed concerning the notion of system of representation evolved. In the analysis of their productions, I identified different kinds or categories of systems of representation. I established symbolic and graphic systems of representation as basic. Systems of numerical and geometric representation were mentioned explicitly in some of the productions, but as alternatives of lesser importance.

In the analysis of the final projects, I showed that the information produced for the systems of representation was the information used most. This information was brought into play especially in the task on cognitive analysis and in the definition of the goals of the didactic unit. However, the putting into practice of the systems of representation was only partial. When using the notion of system of representation in other aspects of the didactic analysis, most of the groups of future teachers limited themselves to the symbolic and graphic systems of representation and did not take the others into account.

As in the case of the notion of conceptual structure, the first productions of the groups of future teachers show the influence of a formal and symbolic view of mathematics. This view was partly overcome when the groups analysed their topic, taking into account a variety of systems of representation. However, the meaning that materialised in most of the groups and that thus was put into practice was limited to the two basic systems of representation: symbolic and graphic.

### *Heterogeneity in Phenomenology*

Phenomenology was the notion that gave the groups of future teachers the most difficulties. These difficulties were expressed in very heterogeneous ways in the partial meanings that the groups developed for it and, therefore, in the multiplicity of approaches they put into practice in tackling the procedures of the phenomenological analysis and in using their results in the design of the didactic unit.

This heterogeneity has to do with the number of phenomena, disciplines and substructures that can be proposed, the variety of the kind of analysis that can be done, and the variety of criteria with which the phenomena can be organised. The difficulties produced by this complexity were expressed in the partial development of their meaning by most of the groups. No group managed to present in its productions a work of phenomenological analysis like that which the instruction expected. However, the analysis of the productions and of the work of the group on quadratic function showed that all of the groups demonstrated an evolution in the construction of this meaning, although this evolution did not follow stable patterns. Both the analysis of the final projects and the work of the group on quadratic function showed that to put into practice complex procedures for the analysis and organisation of the phenomena that correspond to a mathematical topic does

not mean that the resulting information is used in the other aspects of the didactic analysis.

### **12.2. The Complexity of the Curriculum Organisers of the Subject Matter Analysis: Technical and Practical Meanings**

The didactic knowledge of the groups of future teachers who participated in the course evolved gradually, heterogeneously, and out of synch with the instruction. The groups of future teachers faced difficulties when they analysed their topic with each of the curriculum organisers of the subject matter analysis. These difficulties were reflected in their productions and performance in a variety of partial meanings that they brought into play in using each of these notions in practice. Some of the groups of future teachers succeeded in overcoming most of the difficulties. However, some of the goals of instruction were not satisfied, in particular with respect to the notion of phenomenology. These difficulties reflected in part the complexity of the process of initial training of high school mathematics teachers that took place in the course. The difficulties of the groups of future teachers are the product, among other things, of the complexity of these notions, as was shown in the previous sub-section. Nevertheless, the interplay between the technical and practical meanings of the notions also contributes to this complexity.

In this version of the course, the theoretical meaning of the curriculum organisers was not emphasised, although the construction of technical and practical meanings was promoted through specific plans. All of the groups presented the results of the analysis of their topics systematically to the whole class. This meant that each group could compare its work with that of the other groups. Further, each group should have made an effort to critique the work of the other groups and to reflect on and analyse the criticisms received. Comparison with the work of the other groups and recognition of the deficiencies of the solution proposed motivated each group to produce a new solution. This solution was specific to the topic of each group, but it took into account general issues concerning the technical and practical meaning of the curriculum organiser. Therefore, we expected that, as a result of these processes of interaction, the groups of future teachers would succeed in developing knowledge of each curriculum organiser that went beyond issues specific to their topic. In this sense, we hoped that, throughout the course, the groups of future teachers would develop simultaneously and dynamically both technical and the practical knowledge of the notions of didactic analysis, seeking to make these notions into useful instruments for the analysis of any mathematical topic.

This duality in the treatment of technical meaning in the course and the development of knowledge (technical and practical) on the part of the groups of future teachers enables me to explain, at least in part, the lag between the time a curriculum organiser was introduced in the course and the time this notion appeared explicitly in the productions of the groups of future teachers. It was the negotiation of meaning that emerged from reviewing the comments on the transparencies when designing the didactic unit that led the groups of future teachers to reify the meaning of this curriculum organiser and use it explicitly in their productions. That is, bringing the practical meaning into play enabled the group to succeed in reifying its technical meaning. On the other hand, as in the class interaction, the

process of negotiation of meaning that occurred when the groups performed the tasks contributed to the construction of both the technical and the practical meanings. Didactic knowledge was constructed in a constant interplay between the technical and the practical meaning of the notions involved. However, analysis of the final projects shows that the groups gathered information that was relevant for the design of the didactic unit but did not recognise that this information formed part of the information corresponding to each of the curriculum organisers. This is evidence of a weak connection between these two meanings of the notions of the subject matter analysis in the didactic knowledge of the groups of future teachers.

The groups of future teachers also showed difficulties in identifying, differentiating and relating the curriculum organisers of the subject matter analysis. This was clear in the relation between the conceptual structure and the systems of representation and between the systems of representation and the phenomenology.

### **12.3. Development of Didactic Knowledge in the Context of the Course**

The analysis of the presentations showed that it is possible to organise the productions of the groups of future teachers in states of development of didactic knowledge. As was to be expected, the context and development of the course influenced and enabled us to explain different aspects of this development.

The difference in topics can explain, at least in part, the heterogeneity in the groups' presentations and productions. Although all of the topics are framed in a mathematical structure and thus can be tackled with the tools of didactic analysis, some of them seem to make a first approach easier.

Analysis of the productions, interviews and work of the group on quadratic function showed that most of the future teachers arrived to the course with a formal and symbolic view of mathematics. I have already indicated how this view can be one of the causes of some of the difficulties of the groups of future teachers. This view of mathematics led them to think that the topics of high school mathematics were simple. However, as they advanced in the course and analysed their topic with the different notions proposed, the groups of future teachers became aware of the complexity of the topics.

The analysis of the group on quadratic function showed that the information that emerged from the teaching experience of the future teachers was used in several of the work sessions and played, for example, a central role in the completion of the task on cognitive analysis.

Analysis of the productions showed the processes of negotiation of meaning in the classroom. These processes arose from and were promoted by two factors: the methodology of interaction in class and the heterogeneity of advances in the groups' productions.

The review and improvement of the proposals took place in each group's community of practice. The analysis of the work of the group on quadratic function enabled me to describe these processes of negotiation of meaning. In the case of this group's work, one can see a constant attitude of searching for meaning from which confusions and conflicts arose. In general, these confusions and conflicts were overcome, in some cases producing discoveries of meaning. The results of these negotiation processes were the proposals of meaning included in the group's presentations and documents. Some of these proposals ultimately materi-

alised in the group, while others did not and were not used in other places in the didactic analysis.

In the methodological plan of the course, there was no single established authority to decide what was right or wrong in the presentations. The opinions and criticisms of classmates were relevant. Further, there was an atmosphere of healthy competition, in which each group strove to make its project one of the best.

In reducing the importance of the theoretical and formal description of the curriculum organisers, instruction promoted the construction of meanings through the presentation of examples. In fact, on different occasions (e.g., for the first conceptual structure or the design of the didactic unit), the approach that the groups made using each of the notions emerged from imitation.

The final project contributed in a significant way to the construction and consolidation of the meanings that the course developed. The final project led some groups to review and organise what they had done up to that point. This review included analysing the comments on the transparencies, an activity that contributed significantly to the quality of the final proposal.

As is typical of teachers in practice, the future teachers systematically used textbooks in the design of didactic units. The textbooks were a key source of information for the groups of future teachers. However, the main function of the textbooks was evident in the design of the activities for the sessions on the didactic unit.

#### **12.4. Contributions to the Meaning of the Curriculum Organisers of the Subject Matter Analysis: Partial Meanings**

The different studies in general and the study of the productions in particular shed light on the different partial meanings that groups of future teachers can develop about the curriculum organisers of the subject matter analysis. They also show characteristics of these notions of which we were not fully conscious at the start of the project and which we did not emphasise in instruction.

Instruction insisted on the use of systems of representation as the main organising criterion of the conceptual maps with which the mathematical structure was described. However, analysis of two of the difficulties experienced by the groups of future teachers related to this notion suggests other possibilities for organising the conceptual structure: the conceptual approach and phenomenology. Analysis of the productions and the work of the group on quadratic function showed that systems of representation can be classified into four categories and that the productions of the groups of future teachers showed a hierarchy of these categories. The symbolic and graphic systems of representation were identified as fundamental; the numerical and geometric systems were complementary; systems of representation specific to the mathematical structure appeared on very few occasions (e.g., of the matrix for systems of linear equations); and on some occasions, there were proposals that were not systems of representation (for example, phenomena).

The analysis of the productions allowed me to identify different criteria for organising the phenomena: disciplines, families, areas, uses, substructures and groups. But I also characterised the kind of phenomenological analysis revealed in

the productions of the groups of future teachers: a production can present models, laws, substructures, structural analysis of phenomena, and the relationship between the structural characteristics of the phenomenon and elements and relations of the substructure.

### **12.5. Instrumental Genesis in the Group**

The construction and negotiation of partial meanings of a curriculum organiser within a group was an evolving process. Based on the previous analyses, I will now identify the main patterns that characterise this process.

On many occasions, the first problem that the group had to face consisted of understanding the requirements of the task. Since they as yet had no meaning for the curriculum organiser, it was difficult for them to understand what it meant to analyse a topic with this notion. The evidence shows that some groups devoted time to deciding what they should do. In this first approach to the analysis of their topic, many groups resolved the problem by imitating the example that instruction had presented in class and using the tools at their disposal (e.g., the list of curriculum organisers for describing the conceptual structure or textbooks for systems of representation or the design of tasks).

Once they presented their first approach, the groups returned to the analysis of their topic, starting from the ideas, questions, difficulties and possible ways of improving suggested in the comments and criticism they had received, from the analysis and comparison of their work with the work of the other groups and from the information they found in the literature (mainly textbooks). This situation fostered, in general, an intense process of negotiation of meaning within each group. In this process, the groups began to construct techniques (reasoning and procedures) for the analysis of their topic with the curriculum organiser. The notion began to be transformed into an instrument, from the perspective of its technical significance, in the sense that the groups advanced in their capacity to produce and organise the information that emerged from this analysis.

The second phase of the process of instrumental genesis was characterised by two issues: (a) the relation between the future teachers' development of the technical meaning of the curriculum organiser and the depth in which they analysed their topic and (b) the relationship between the construction of this technical meaning and putting it into practice.

In the process of transforming a curriculum organiser into an instrument, the analysis of the mathematical structure and the construction of the technical meaning of the notion interacted dynamically. As the group advanced in the analysis, they constructed more complex meanings (of the curriculum organiser and the concept) that in turn enabled new and deeper analyses. The characteristics of the groups' transparencies depended on two factors: the technical meaning that the groups were constructing from each curriculum organiser and the depth in which they studied and analysed (using this notion as instrument) the mathematical structure that corresponded to their topic. A preliminary technical meaning of the curriculum organiser allowed only a general description of the mathematical structure. And the effort to deepen the analysis of the mathematical structure contributed to the development of the technical meaning of the notion. For example, in the first productions on conceptual structure, when the meaning of this curricu-

lum organiser was just beginning to be constructed, the groups of future teachers presented productions that described the mathematical structure in a general and only slightly organised way. However, this effort led them to understand this mathematical structure better and, at the same time, to progress in the development of the meaning of the curriculum organiser with which they analysed it (in this case, the conceptual structure). In this way, the groups of future teachers moved from using a multiplicity of organisation criteria to organising the conceptual structure based on systems of representation. This allowed them to describe and understand the mathematical structure in greater detail, which led them for example to recognise the importance of the connections between systems of representation.

The groups also advanced in the construction of the technical meaning of each curriculum organiser when they tried to put the information that emerged from their analysis into practice. This was the case, for example, with the notion of connections in the work of the group on quadratic function. This group did not recognise the importance of this notion when it produced the conceptual structure. The notion appeared explicitly for the first time when they performed the cognitive analysis. But because of the negotiation of meanings that arose from the review of the comments on the transparencies when designing the didactic unit, the group reified the meaning of this notion and captured it explicitly in its productions. That is, it was because of putting into practice the result of the analysis of their topic that the group succeeded in materialising its technical meaning. Therefore, the technical and practical meanings of a curriculum organiser interact in two ways: first, practical meaning is developed when the information that emerges from the analysis of the topic is brought into play with the curriculum organiser (technical meaning); second, the groups advance in materialising the technical meaning of the curriculum organiser when they construct its practical meaning.

That a group developed and materialised the technical meaning of a curriculum organiser did not necessarily mean that it advanced in the construction of its practical meaning. All of the studies provide evidence that this was the case for the notion of phenomenology. In the analysis of the work of the group on quadratic function, I presented a detailed description of this situation. There I showed that the group had difficulties in identifying the procedure for phenomenological analysis by which substructures were identified and relationships between these substructures and the corresponding phenomena established. However, careful reading of the comments on the transparencies ultimately enabled them to identify the procedure and put it into practice. This suggested an important advance in the construction of the technical meaning of the notion of phenomenology. However, this meaning did not materialise from the practical point of view. In designing the activities for the didactic unit, the group did not use the information that it gathered and organised for this notion.

Deficiencies in the development of the practical meaning of the curriculum organisers by the groups of future teachers were also revealed in the lack of connection between the work that the groups performed with the curriculum organisers of the subject matter analysis and the design of the didactic unit. This was demonstrated in the analysis of the final projects. There, I showed that most of the groups used information in the design of the didactic unit that was not registered

in the corresponding place in the didactic analysis. This means that the groups found that this information was relevant for the design but did not recognise that it formed part of the information corresponding to each of the curriculum organisers.

### **12.6. Theory, Technique and Practice in the Instrumental Genesis of the Curriculum Organisers**

The foregoing analyses suggest the possibility of describing more precisely the process of instrumental genesis in the context of the development of didactic knowledge of the curriculum organisers. I have identified stages and relationships in the development of the meanings of these notions for the groups of future teachers.

The development of the didactic knowledge of a group concerning a curriculum organiser begins with the negotiation of the meaning of the requirements involved in the tasks assigned to them (analysis of their topic with the notion). On many occasions, the first approach arises from imitation: they adapt the example from instruction to their topic and complete it with information that they find in the textbooks. In the second stage, due to the comments and critiques that emerge from their presentation and from comparing their work with that of the other groups, they advance in the construction of technical meaning. There are two catalysts in this progress. First, as the future teachers deepen their analysis of the mathematical structure, they advance in constructing the technical meaning. Second, this technical meaning also develops from being put into practice in the other analyses of the didactic analysis and in the design of the didactic unit. In a third stage, they manage to establish techniques for the technical analysis of the topic with the curriculum organiser. The development of the practical meaning of the notion constitutes the fourth stage. Finally, the fifth stage consists of developing the techniques for using this practical meaning.

The groups were not necessarily aware of the theoretical meaning of the curriculum organisers. This does not mean that they did not manage to develop it in some way. The fact that the groups managed to interpret and adapt the productions of other groups to the specific case of their mathematical topic indicates that their knowledge of the curriculum organiser went beyond the characteristics specific to their topic. In this sense, the groups managed to generalise the technical significance of the curriculum organiser and thus to construct preliminary versions of its theoretical meaning. However, in practice the groups focused their attention on the construction of the technical and practical meanings of the notions. Didactic knowledge was thus constructed in a constant interplay (in most cases unconscious) between the theoretical, technical and practical meaning of the notions involved.

The interaction between technique and practice is characterised by the role that practice plays in the development of technical meaning and by the role played by the information that emerges from the technical analysis of the topic in practice. In the case of the development of the course that I have analysed in this research project, the groups succeeded in developing the technical meaning of conceptual structure and of systems of representation and in developing it partially for phenomenological analysis. In some cases, they also managed to develop tech-



niques for the analysis of the topic with the three curriculum organisers. However, they did not manage to develop techniques for putting it into practice.

Figure 103 diagrams a preliminary conjecture about the process of instrumental genesis of the curriculum organisers in the context of the course. A group of future teachers transforms a curriculum organiser into an instrument (and, therefore, advances in the development of its didactic knowledge about the notion) as it negotiates and constructs its theoretical, technical and practical meanings. The process begins with the construction of a preliminary technical meaning of the notion, motivated by imitation and nourished by information from textbooks. This is the beginning of the process of instrumentalisation (technical). Instrumentation takes place when the technical meaning is developed, through the comments and criticisms, in their interaction with the in-depth analysis of the mathematical structure and its putting into practice in other analyses and in the design of the didactic unit (orchestration). This development leads to the construction of techniques for the technical analysis of the mathematical structure. As the capacity to compare and interpret the technical analyses of different mathematical topics develops, the theoretical meaning of the notion is constructed. The development of practical meaning requires a new process of instrumental genesis. This emerges from the information that arises from the technical analysis of the topic and calls for the orchestration of different instruments (curriculum organisers) for the construction of techniques that lead to the putting into practice of the curriculum organiser for didactic purposes.

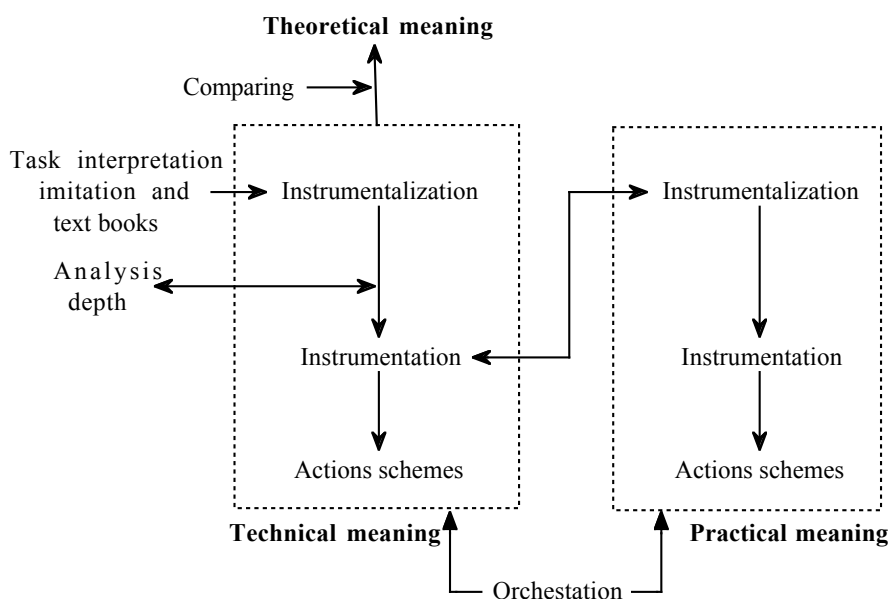

Figure 103. Conjecture concerning the instrumental genesis of the curriculum organisers

## 13. ONE STAGE IN MY REFLECTION ON THE HIGH SCHOOL MATHEMATICS TEACHER

I framed this research project in the context of four general questions on the mathematics teacher that refer to his performance, his knowledge, the design and development of initial training programs for high school mathematics teachers and the learning processes of the future teachers who participate in these programmes. I specified these questions with two general goals for the project: (a) to advance in the conceptualisation of the activities and didactic knowledge of the high school mathematics teacher and the design of initial training plans and (b) to describe and characterise the development of didactic knowledge of the groups of future teachers who participated in the course Mathematics Education in High School at the University of Granada in the 2000-01 academic year.

I believe that I have proposed specific answers to the four general questions that structured this project in tackling the general and specific objectives that structured the investigation I have reported in this document. Now, to justify and illustrate this assertion, I will describe the issues that I consider most relevant to the reflection and investigation I have performed. To do this, I identify the main contributions of this project, establish some of its implications, determine its limitations and record the questions that remain unresolved.

### 13.1. Contributions to Thinking on the High School Mathematics Teacher

I believe that this research project contributes to thinking on the high school mathematics teacher in general and on the initial training of high school mathematics teachers in particular. These contributions are theoretical, methodological, empirical and curricular.

#### *Theoretical Contributions*

I proposed didactic analysis as a curriculum level. With this idea, I conceptually structured the curriculum organizers proposed by Rico (Rico, 1997a). I showed advances in the conceptualisation of the notion of “curriculum organiser” by using the theory of instrumental genesis to give concrete meaning to the idea of “conceptual and methodological tool”.

In the description of the subject matter analysis, I introduced the notion of conceptual structure as a curriculum organizer, specifying one of the aspects of the meaning of concepts of school mathematics without having to refer to cognitive questions. In emphasizing the operations performed on signs, I established the link between conceptual structure and systems of representation. This distinction enabled me to characterize the connections that can be established between the elements of a mathematical structure when it is represented by means of conceptual maps. I developed thinking on phenomenology as a dimension of the meaning of a concept in greater depth when I clarified the link between substructures of a mathematical structure and the phenomena that these substructures organize using a specific and operational formulation of the notion of mathematical model.

The grounding of these three dimensions of the meaning of a concept in school mathematics that structure subject matter analysis are based on Luis Rico’s contributions to the interpretation and adaptation of the notion of meaning from

Frege in this context. Rico's contributions also allowed me to structure and describe in greater detail the notion of content as a curricular element.

I introduced the notion of "learning path" as an adaptation of the idea of hypothetical learning trajectory to the initial training of high school mathematics teachers. I conceptualised the relationship between the notions of learning objective, capacity, task, learning path and competence. This conceptualisation led to the formulation of a procedure that enabled me to characterise a learning objective in terms of its learning paths, as well as another procedure by which it is possible to analyse and select tasks that contribute to achieving the learning objective. I thus emphasised the link between subject matter analysis, cognitive analysis and instruction analysis.

Based on the notion of didactic analysis and starting from a functional view of the initial training of high school mathematics teachers, I established a specific meaning for the term "didactic knowledge" and showed its relation to the notion of pedagogical content knowledge. I introduced the notions of theoretical, technical and practical meaning of the curriculum organizers from the perspective of the didactic reference knowledge and adapted these notions to the context of the didactic knowledge of the future teachers, grounding my argument in the notion of the partial meaning of a group of future teachers. The proposals for the notion of didactic analysis and didactic knowledge enabled me to characterise the mathematics teacher's planning competence in terms of capacities. I believe that these conceptualisations ground possible answers to both the paradox of planning and the problem of the gap between global and local planning and represent an advance in thinking on the notion of pedagogical content knowledge.

Although they do not qualify as theoretical contributions, I believe that this research project has introduced conceptual innovations that contribute to reflection and research on the mathematics teacher. I adapted the theory of instrumental genesis to the initial training of high school mathematics teachers in general and the study of the development of didactic knowledge of curriculum organizers in particular. I used the theory of quality of information to justify a methodological analysis of the productions of future teachers and to introduce the notion of "development factor". I tackled the problem of the learning of the future teacher of mathematics from the perspective of Wenger's social theory of learning. My interpretation and adaptation of these three theories to the context of this project enables me to establish a meaning for the notion of "development of didactic knowledge" that I have made methodologically operational.

#### *Methodological Contributions*

In the context of the line of research on teacher training from the Group on Numerical Thinking, I introduced several innovations in the design of the empirical studies that configure this research project. I assumed a socio-cultural position on learning and focused investigation on the learning of groups of teachers, relegating analysis of the performance and productions of the future teachers as individuals to second place. I decided to study the learning processes (development of didactic knowledge) rather than the results. And I performed this investigation in the context of the course.

In the analysis of the productions, I designed and put into practice a methodology for analysing the observations, the discrepancy analysis, which allowed me to establish and characterise the four states of development of didactic knowledge and to assign each observation to one of these states. This is a non-standard procedure for grouping observations that can be used when the information available does not satisfy the conditions imposed by standard methods for grouping, such as cluster analysis. I designed a spreadsheet that enabled me to automate my use of the method and identified the method's virtues and defects. For analysing the productions, I designed an interconnected system of databases that allowed me to navigate dynamically through the evidence included on the transparencies of the groups of future teachers and the transcriptions of the audio recordings of class interaction.

To analyse the work of the group on quadratic function, I designed and put into practice instruments for the codification, analysis and interpretation of the transcriptions that make Wenger's social theory of learning operational in the context of the initial training of high school mathematics teachers. With this adaptation of the theory, I showed that the notion of community of practice is constituted as a tool for "seeing, thinking and acting" in the area of teacher training.

Being a systematic analysis of school mathematics, I believe that didactic analysis can be useful conceptually and methodologically in studies of the learning of mathematical topics in which it is necessary to design instruments for analyzing the performance of subjects when they tackle tasks. Didactic analysis (in particular, subject matter analysis) has already been used in research related to this problem and to the historical analysis of textbooks.

#### *Empirical Contributions*

The purpose of the empirical studies that configure this research project was to provide a "proof of existence", that is, to present systematic evidence of a case in which a strategy (of training) produces certain results. A proof of existence is a contribution to knowledge in Mathematics Education, since each researcher and trainer of teachers can interpret and adapt the results of these empirical studies to his specific context and to the problems that are articulated in that context. I will now list the main contributions of these studies.

I established that didactic knowledge of the groups of future teachers evolves according to stable patterns and characterised four states of development. I showed that the process of instrumental genesis takes time: it requires that the groups of future teachers negotiate meanings (of the curriculum organizer, of their mathematical topic and of their techniques) and that these partial meanings materialize (in different forms) on the successive occasions that the groups present their productions in class.

I developed in greater depth the description of these states of development by identifying and detailing the partial meanings that the groups of future teachers constructed throughout the course, thereby contributing to the characterisation of the curriculum organisers from an empirical perspective. I showed the evolution of these partial meanings in terms of development factors, identified the difficulties that the groups of future teachers showed at different moments and reviewed the ways and strategies with which they overcame these difficulties on different

occasions. I showed the role of teaching experience and of the views of the future teachers when they entered the course in their development of didactic knowledge.

I established to what extent and in what way the groups of future teachers brought into play the information they obtained for the curriculum organisers in the design of the didactic unit. I demonstrated that several groups of future teachers did not necessarily develop a global and integrated view of subject matter analysis as a tool for the design of didactic units.

I detailed the process by which a group of future teachers constituted a community of practice, when I showed how their mutual commitment evolved, how they defined and fine-tuned their joint enterprise and how they developed their shared repertoire. I characterised the learning of a group of future teachers from a socio-cultural perspective by showing the processes of negotiation of meaning that gave rise to their productions and performance. I identified and described the main questions that influenced this process of negotiation of meaning.

Based on the previous results, I deepened and developed more specifically from an empirical perspective the notions of the theoretical, technical and practical meaning of the curriculum organisers and detailed the process of instrumental genesis in the context of the initial training of high school mathematics teachers. I thus characterised the interplay between theoretical, technical and practical knowledge of the future teachers that grounds the transformation of a curriculum organiser into an instrument with practical utility. I identified some phases of this transformation process, as a contribution to the understanding and conceptualisation of the development of the didactic knowledge of the groups of teachers. I showed the role that the design and development of the course played in this process and identified other characteristics of the course and of the future teachers that influenced the development of their didactic knowledge.

#### *Curricular Contributions*

I believe that I have contributed to the conceptualisation and grounding of the course on Mathematics Education in High School in particular and of the initial training of high school mathematics teachers in general. These contributions are based on my contributions to the specification of meaning of the notions of didactic analysis and didactic knowledge and to the characterisation of the planning competence of the mathematics teacher that arises from them. I showed how these notions enable us to put our functional view of the initial training of high school mathematics teachers into curricular practice.

I believe that I have also contributed to the design of the course from the methodological point of view by proposing and contrasting empirically a work plan for the treatment of didactic analysis in this training programme.

#### **13.2. From Research to Practice**

How can the “proof of existence” that I have just described contribute to the practice of the initial training of high school mathematics teachers? I believe that these results can be interpreted and adapted in two areas: evaluation and improvement of the design and development of initial training programmes for high school mathematics teachers and reflection on the performance of the trainers of teachers.

My intention in this project was not to evaluate a model for initial training of high school mathematics teachers. Therefore, I do not try to answer questions like, “What works in the classroom?” or “What is the best method?”. Rather, I argued that the characterisation of the development of didactic knowledge of the groups of future teachers who participated in the course sheds light on their difficulties and achievements in performing tasks and on the possible causes of these difficulties and achievements. I understand that this information is both relevant for revising the design of the course and, subject to interpretation, to other trainers and other courses that in some way ground initial training of high school mathematics teachers on a model like ours. In the case of our course, the results emphasise two key areas in which it is necessary to improve: the treatment of the phenomenological analysis and the presentation of the practical meaning of the curriculum organisers and its relation to their technical significance. Yet these questions also emphasise the positive role played by the methodological plans used and the comments on the productions of the future teachers.

I believe that the detailed description of the process by which the groups of future teachers constructed their partial meanings for the curriculum organisers from the subject matter analysis provides valuable information for trainers of teachers who seek to promote these meanings in their students. This information can in many cases enable us to foresee the performance of groups of future teachers and thus to plan appropriate instruction.

The analysis of the process by which a group of future teachers emerged as a community of practice emphasised the role of the trainers as promoters of interdependent learning and negotiation of meaning. I have suggested that as trainers we should assume a role of “advisors”, in which our concern focuses not only on what a group of future teachers learns but also on the factors that can influence both the development of mutual commitment among its members and the clarity and validity of its joint enterprise.

### **13.3. Limitations and Unresolved Questions**

In this section, I identify the main limitations of this project and establish some of the questions that remain open for the future.

Didactic analysis is a partial and ideal view (conceptualisation) of the activity (of planning) of the mathematics teacher. It is a partial view, because it focuses attention on the local dimension of planning. The fact that there are other aspects of this activity that I do not consider in didactic analysis does not mean that these issues are not important or relevant or that they are less important than those I explored in this document. As an ideal procedure, it served to conceptualise the didactic knowledge of the mathematics teacher and detail in terms of capacities some aspects of his planning competence. I do not expect any specific mathematics teachers to perform systematically each and every one of the procedures that compose didactic analysis. However, I have shown that in planning his class the teacher can use didactic analysis as a guide, at a level of detail appropriate to the time he has available.

Although I took considerable care to ground the subject matter analysis conceptually, I do not believe that this work is finished. The clarity and usefulness of the technical meaning of the curriculum organisers depends on the depth and clar-

ity with which their theoretical meaning is structured. On the other hand, the empirical studies showed the need to explore and develop strategies for the description and curricular treatment of the practical meaning of the curriculum organisers. My presentation of cognitive, instruction, and performance analysis is limited and tackles only some of their multiple aspects. In fact, the first two are currently the object of study in our research group. We are also currently exploring the links between didactic analysis —as a notion for grounding a training programme for teachers— and the training of the students, in particular from the perspective of mathematical literacy.

I proposed a preliminary conjecture for the process of instrumental genesis of the curriculum organisers in the context of the course. This conjecture requires significant structuring and theoretical grounding and fuller empirical support. In particular, it is necessary to explore in greater depth how successful groups of future teachers construct the practical meaning of curriculum organizers in practice.

I focused the conceptual and methodological efforts of this project on the teacher's planning competence. However, didactic analysis includes the full cycle of planning, putting into practice and evaluating the didactic units. Two questions thus arise as possibilities for research and development. On the one hand, we should ask how we should advance in a description of didactic analysis that can be used for grounding an initial training plan for high school mathematics teachers that includes the possibility that groups of future teachers put their proposals into practice for the didactic unit. On the other, it is also relevant to question how didactical analysis can be adapted as a foundation for continuing education programmes for high school mathematics teachers.

As I mentioned in the previous section, the area of the competences of the trainer of mathematics teachers is a relevant and little explored one. The results of the studies show the need to investigate which competences trainers should develop if they adopt a socio-cultural view of the learning of future teachers.

#### **13.4. The End of one Stage; the Beginning of Another**

In this document, I report the activities and results of a collective project. In many places, I indicate how the activities of design, development and research were performed in a team and how this project was framed and supported by activities and results of a line of research on training teachers in the Group on Numerical Thinking, which Luis Rico has been directing, promoting and developing since the late 80s. The achievements of this project contribute to a collective long-term research process and are the product of his view and capacity to incorporate this process and direct this research project.

From the personal perspective, this report describes the path that I, as designer, trainer and researcher, travelled over seven years, in my relation to the initial training of high school mathematics teachers in general and to one training programme in particular. In this sense, I report research on my own practice. The conceptualisation and design of the research tell of my beliefs, values and attitudes as a designer and researcher. The empirical results reveal aspects of my competences and attitudes as a trainer of teachers of mathematics.

My experience on ending this new stage in my journey as designer, trainer of teachers and researcher makes one question clear: the complexity of the initial

training of high school mathematics teachers. This experience has enabled me to perceive and tackle in part the multiplicity of dimensions involved in this complexity. On the conceptual level, in my approach to didactic analysis, didactic knowledge and the learning of future teachers. On the curricular level, in my research on the design and development of initial training plans for high school mathematics teachers and on the role of trainers in them. And on the research level, in the importance of exploring and understanding the processes from which the learning of future teachers emerges. My awareness of the complexity and crucial importance of the initial training of teachers of high school mathematics leads me to consider this document as the beginning of a new stage in my reflection on the mathematics teacher.